

**Enjoy peace of mind.  
Register your appliance today.**

Stay updated on better living services, safety notices and shop for accessories.

**1. Open the camera app on your smartphone and point at the QR code to scan**

Product Registration QR code is located on the front of your appliance or inside the door rim\*.

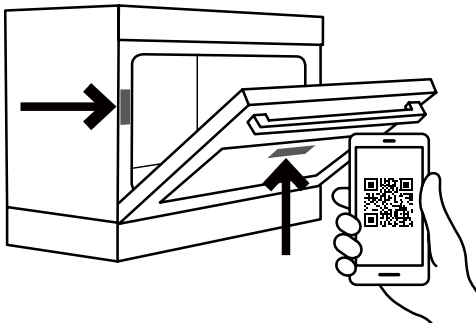

**2. Tap the notification or link to open the registration form**

**3. Complete your details and enjoy peace of mind**

\*Exact location of QR code may vary depending on oven model

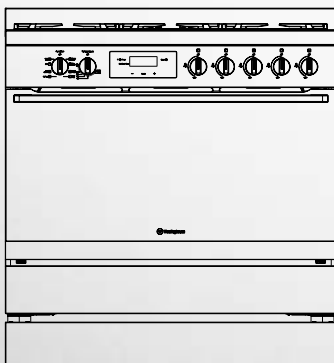

## **90cm COOKING APPLIANCES**

WFE9515SD

## CONGRATULATIONS

Congratulations and thank you for choosing our product.

We are sure you will find your new cooker a pleasure to use and a great asset to your cooking. Before you use the appliance, we recommend you read through the whole user manual which provides a description of the product and its functions.

To avoid the risks that are always present when you use an appliance, it is important that the appliance is installed correctly and that you read the safety instructions carefully to avoid misuse and hazards. We recommend that you keep this instruction booklet for future reference and pass it on to any future owners.

This appliance complies with the requirements of Australian Standard AS/NZS 60335.2.6. Gas appliances also comply with the requirements of AS/NZS 5263.1.1.

### Conditions of use

This appliance is intended to be used in household and similar applications such as:

- Staff kitchen areas in shops, offices and other working environments
- Farm houses
- By clients in hotels, motels and other residential type environments
- Bed and breakfast type environments

**Please ensure you read the instruction manual fully before you call for service, or a full service fee could be applicable.**

Record model and serial number here:

Model number:.....

Serial number:.....

PNC:.....

## CONTENTS

Important safety instructions .....	3
Product description .....	5
Installation of the appliance.....	6
Wiring requirements.....	16
Installing the freestanding cooker .....	17
LPG conversion gas cooktop .....	18
Testing the operation of the gas cooker.....	19
Before operating your appliance for the first time.....	20
Installing your oven accessories .....	21
Installing burners and trivets.....	22
Getting to know your cooktop.....	23
Using your oven .....	24
Cooking Test.....	28
Cooking Guide.....	30
Cleaning your oven accessories.....	34
Troubleshooting .....	36
Warranty.....	39

Please read the user manual carefully and store in a handy place for later reference.

The symbols you will see in this booklet have these meanings:



### WARNING

This symbol indicates information concerning your personal safety.



### CAUTION

This symbol indicates information on how to avoid damaging the appliance.



### IMPORTANT

This symbol indicates tips and information about use of the appliance.



### ENVIRONMENT

This symbol indicates tips and information about economical and ecological use of the appliance.

## IMPORTANT SAFETY INSTRUCTIONS

### IMPORTANT INFORMATION THAT MAY IMPACT YOUR MANUFACTURER'S WARRANTY

Adherence to the directions for use in this manual is extremely important for health and safety. Failure to strictly adhere to the requirements in this manual may result in personal injury, property damage and affect your ability to make a claim under the Westinghouse manufacturer's warranty provided with your product. Products must be used, installed and operated in accordance with this manual. You may not be able to claim on the Westinghouse manufacturer's warranty in the event that your product fault is due to failure to adhere to this manual.

Please read the user manual carefully and store in a handy place for later reference. Pass the user manual on to possible new owners of the appliance.

Read the following carefully to avoid damage or injury.

**NOTE: You must read these warnings carefully before installing or using the appliance. If you need assistance, contact your Customer Care Department. The manufacturer will not accept liability, should these instructions or any other safety instructions incorporated in this book be ignored.**



### WARNING

#### General warnings

- This appliance must not be used as a space heater.
- In order to avoid fire, the appliance must be kept clean and vents kept unobstructed.
- Do not spray aerosols in the vicinity of this appliance whilst it is in operation.
- Do not use or store flammable materials in this appliance storage drawer or near this appliance.
- Do not line the bottom of the oven with foil or cookware.
- Always use gloves when handling hot items inside the oven.
- Always turn the grill off immediately after use as fat left behind may catch fire.
- Do not hang any objects from the hob as it may block the air vents.
- Do not modify this appliance.
- To maintain safe operation, it is recommended that the product be inspected every 5 years by an authorised service person.
- Do not install an aftermarket lid or cover over this appliance.
- The cooking process must be supervised. A short term cooking process must be supervised continuously.

### Installation, cleaning and servicing

- An authorised person must install this appliance. (Certificate of Compliance to be retained).
- Before using the appliance, ensure that all packing materials are removed from the appliance.
- In order to avoid any potential hazard, the enclosed installation instructions must be followed.
- Ensure that all specified vents, openings and airspaces are not blocked.
- Where the appliance is built into a cabinet, the cabinet material must be capable of withstanding 85°C.
- Only authorised personnel should carry out servicing. (Certificate of Compliance to be retained).
- Always ensure the appliance is switched off before cleaning or replacing parts.
- Do not use steam cleaners, as this may cause moisture build up.
- Always clean the appliance immediately after any food spillage.
- This appliance must be earthed.
- Due to the weight (freestanding 95-100kg) and size of cookers, 2 persons are required to manually manoeuvre them. Remove loose items such as trivets, oven racks and trays to minimise weight.
- Do not use the handle to lift the cooker, instead open the oven door and lift the roof of the oven cavity.
- Take care when lifting to avoid any sharp edges not intended for lifting.
- This cooker must not be installed with a cut-off timer.
- Disconnection in the fixed wiring must occur in accordance with AS/NZS 3000 wiring rules.
- This appliance must be fixed in position or must be connected to the supply by a supply cord fitted with a male connector

## IMPORTANT SAFETY INSTRUCTIONS



### WARNING

#### Oven

- During use the appliance becomes hot. Care should be taken to avoid touching the hot surfaces inside the oven.
- Switch the appliance off at the isolating switch before removing the oven light glass for globe replacement.
- To avoid an accident, ensure that oven shelves and fittings are always inserted into the appliance in accordance with the instructions.
- Do not use the door as a shelf.
- Do not push down on the open oven door.
- Do not cover the grill insert with foil, as fat left there may catch fire.
- Always keep the grill dish clean as any fat there may catch fire.

#### Gas cooktops

- Do not allow pots to boil dry, as damage to both pan and cooktop may result.
- Do not operate the cooktop for an extended period of time without a pot or pan on the burner.
- Do not allow large cookware to overhang the cooktop onto the adjacent benchtop. This will cause scorching to the benchtop surface.
- Do not allow cooking pots or pans to intrude into the area which is close to the controls.
- Ensure burner bodies and trivets are properly located.
- Unattended cooking with oil or fat on a hob can be dangerous and result in fire.
- In order to avoid a fire do not store items on the cooking surface.



### WARNING

#### Child safety

- This appliance is not intended for use by persons (including children) with reduced physical, sensory or mental capabilities, or lack of experience and knowledge, unless they have been given supervision or instruction concerning use of the appliance by a person responsible for their safety.
- Children should be supervised to ensure that they do not play with the appliance.
- During use this appliance becomes hot. Care should be taken to avoid touching hot surfaces, e.g. oven door, heating elements etc.
- Accessible parts will also become hot when in use. To avoid burns and scalds children should be kept away.
- Always turn pan handles to the side or rear to prevent accidental knocking and to keep out of reach of children.

## PRODUCT DESCRIPTION

Freestanding cooker with flame safeguard gas cooktop and multi-function electric oven

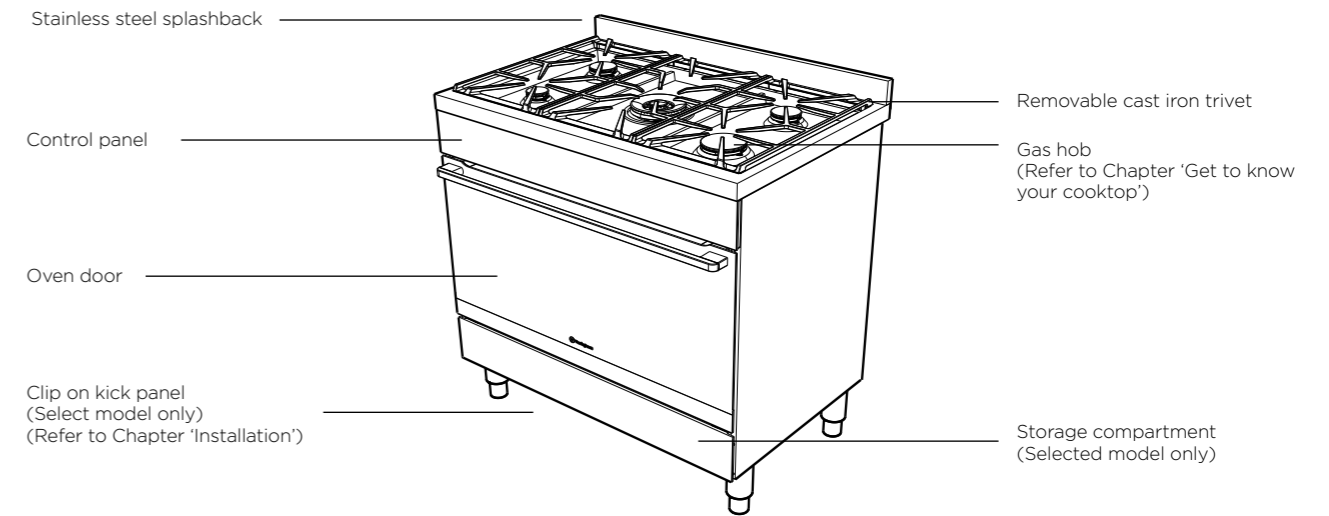

### Control Panel

Model WFE9515SD

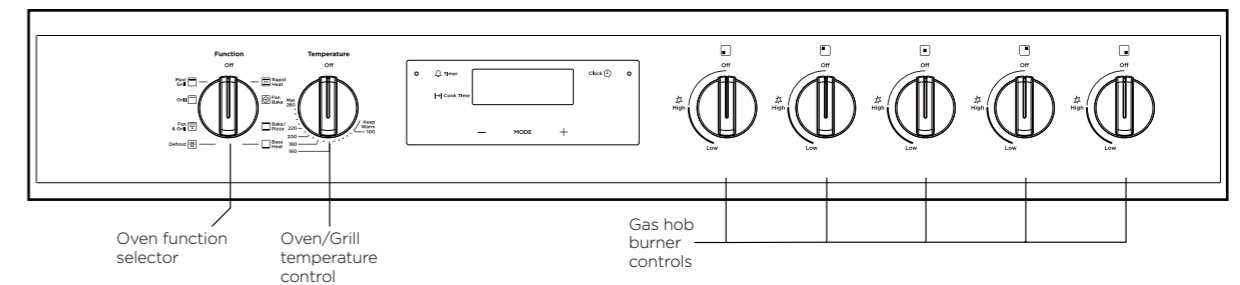

## INSTALLATION OF THE APPLIANCE

### Cabinet requirement

Model **WFE9515SD** is designed to fit into a 900mm wide gap between standard kitchen cabinets. The appliance integrates with the kitchen cabinets by matching the height, depth and kick panel. The cooker may also be installed at the end of a line of benches or with a free space either side. In addition, a slot-in type installation is catered for allowing a continuous cabinetry kick panel to be used.

### ⚠ WARNING

- The cooker must be installed and serviced only by an authorised person.
- A Certificate of Compliance **MUST** be supplied to be kept by the customer.
- The packing materials must be removed before you install the cooker.
- The surrounding kitchen cabinets must be able to withstand 85°C. Electrolux **WILL NOT** accept responsibility for damage caused by installation into kitchen cabinets which cannot withstand 85°C.
- The pipes used for installation **MUST** have sufficient loops so the cooker can be moved for service (gas models).
- The vents, openings and air spaces **MUST NOT** be blocked.
- Two anti-tilt brackets are supplied and stored in the base of the packaging
- The anti-tilt brackets and chain or front stops **MUST** be installed to avoid accidental tipping (freestanding and slot-in models).
- You **MUST NOT** lift or pull the cooker by the door handle.
- The cooker **MUST** be checked every five years.
- If the supply cord is damaged, it must be replaced by the manufacturer, its service agent or similarly qualified persons in order to avoid a hazard.
- The appliance must not be installed behind a decorative door in order to avoid overheating.
- Due to the weight (95-100kg) and size of the cooker, 2 persons are required to install it.

### Gas model clearance requirements

- Ensure the appliance is installed in accordance with AS/NZS 5601.1 or AS/NZS 5601.2 with regard to clearances to combustible surfaces and materials, and clearances to rangehoods and exhaust fans, to ensure clearances of 200mm from burners to vertical combustible surfaces observe the minimum dimension of 100mm from each side of the cooker to combustible surfaces.
- Clearances to combustible surfaces may be reduced

if combustible surfaces are protected in accordance with AS/NZS 5601.1, or AS/NZS 5601.2.

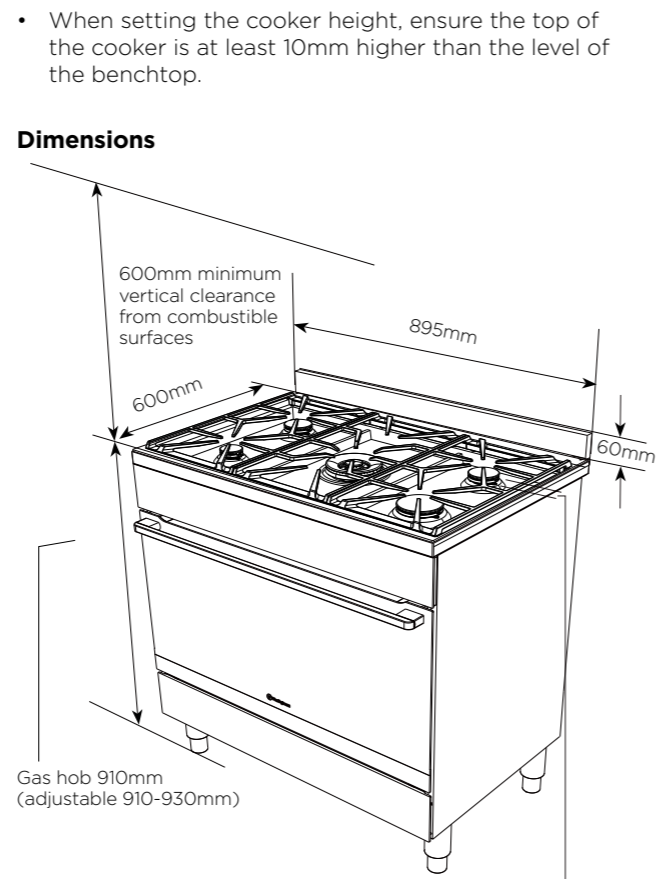

### Splashback

The splashback is secured to the back of the cooker. **REMOVE** the splashback before installing the feet.

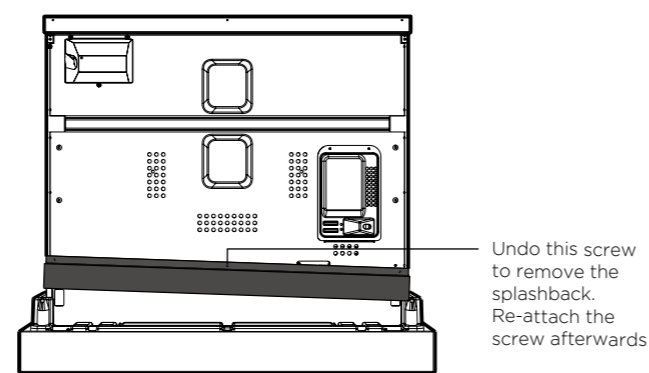

## INSTALLATION OF THE APPLIANCE

### Freestanding installation

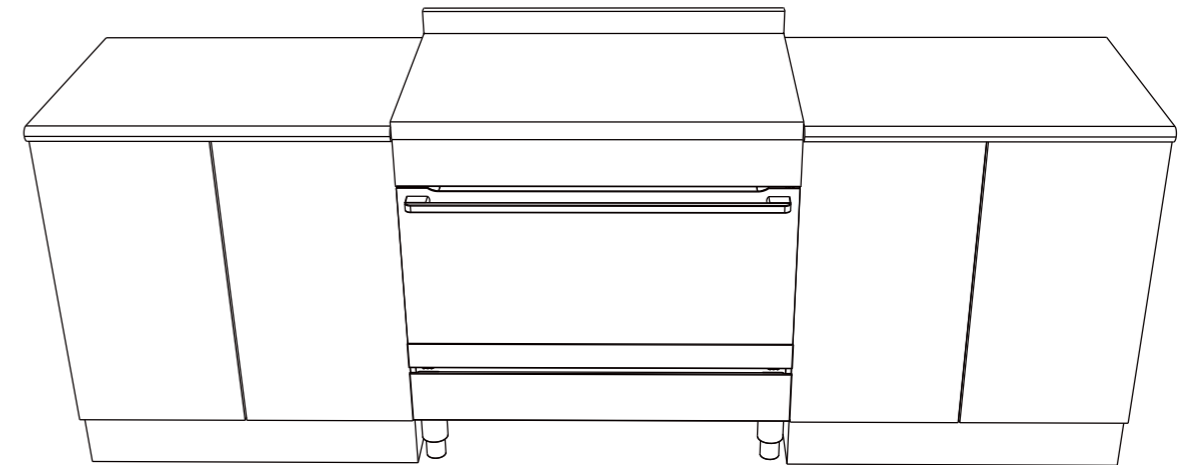

The freestanding type installation requires four screw-in feet to be installed before it can be fitted in between cabinets, with cabinets on one side or without adjacent cabinets. There is no clearance requirement to adjacent side cabinets.

To ensure cooker stability, the anti-tilt brackets must be installed.

Four screw-in feet are supplied with the appliance and can be found in the accessories pack in the oven. WFE9515SD is supplied with a clip-on kick panel.

### Cabinet construction for freestanding installation

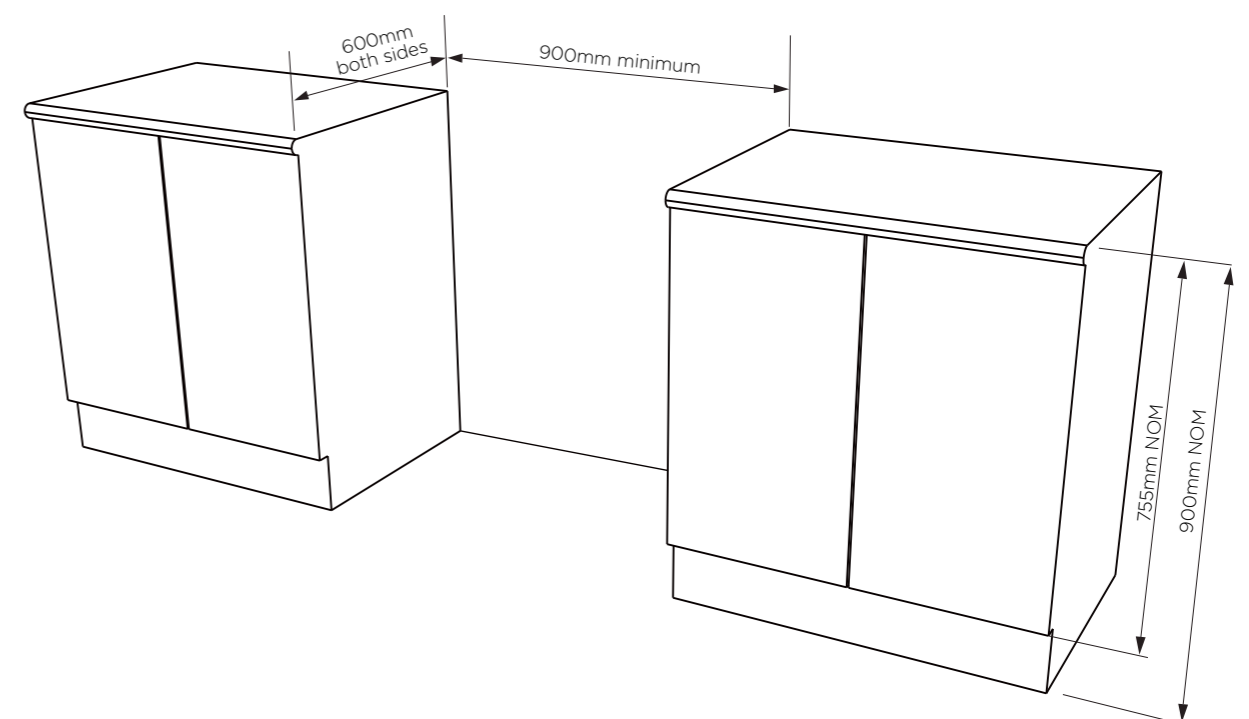

## INSTALLATION OF THE APPLIANCE (CONTINUED)

### Freestanding installation (continued)

#### Installation of screw-in feet

- Freestanding appliances are supplied with four screw-in feet in the internal accessory pack. The screw-in feet can be adjusted by turning the lower half clockwise or anti-clockwise.

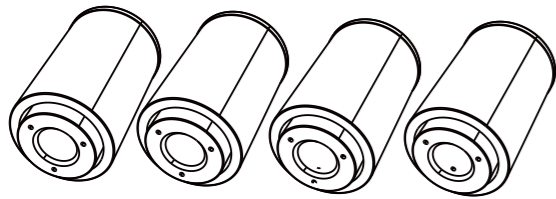

#### **i** IMPORTANT

- Your cooker is supplied with two silver feet and two black feet, it is recommended to install the two silver feet at the front of the appliance for the best aesthetics.
- If the appliance is a gas hob model, remove the burner cap and burner crown. Store all items safely, away from the installation area.

You MUST remove the oven door before commencing installation

Locking tab up at normal position

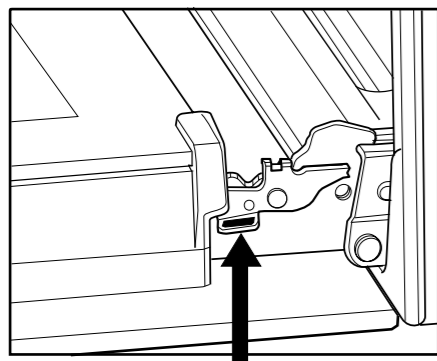

Press the locking tab down for removing the door.

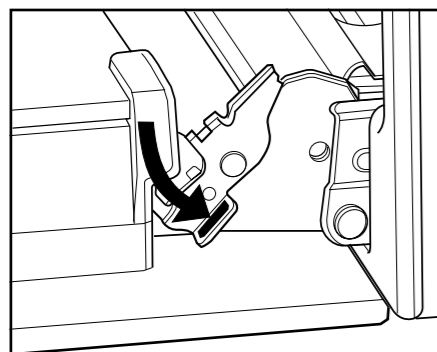

Gently close the door until it comes to a stop. Then lift the door off the hinge.

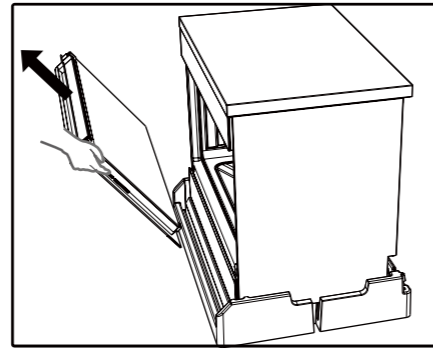

Tilt and carefully lay the appliance on its back to gain access to the installation point for the screw in feet.

#### **!** CAUTION

- To avoid scratching the floor and the appliance itself, fold the packaging carton board and place it underneath the appliance as protection.
- The cooker MUST be laid on its back when installing the feet.

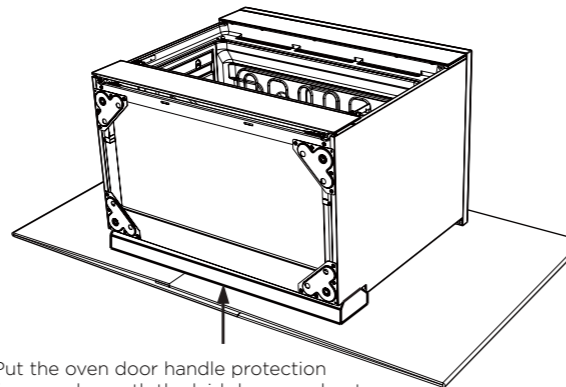

Put the oven door handle protection foam underneath the laid down cooker to protect your cooker when putting it upright

Install the four supplied feet via the four installation points. Make sure that each foot is securely fastened.

#### **!** CAUTION

Do not over-torque the foot.

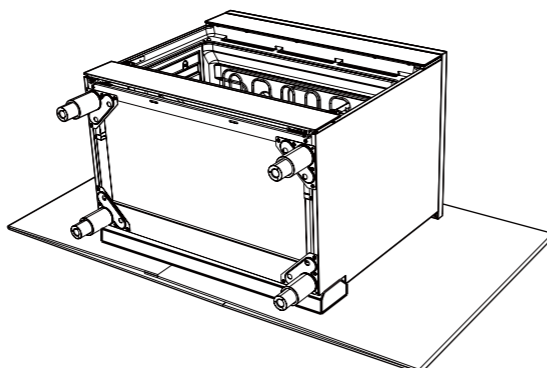

Adjust the height of the screw-in feet to make sure the hob surface is 10mm above the bench when appliance is upright.

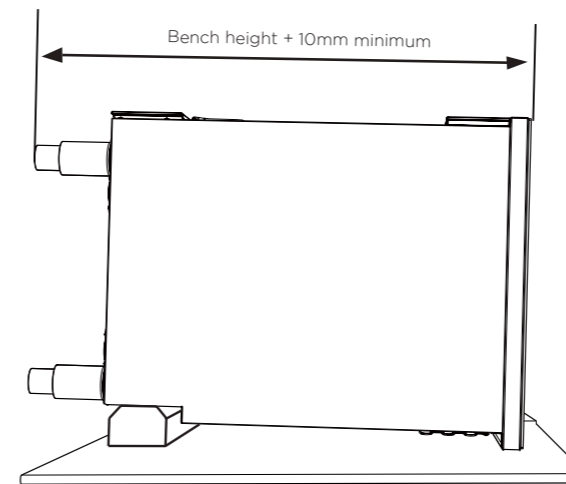

If your kitchen has a 900mm height kitchen bench top, follow the quick measurement guide below before putting the cooker upright

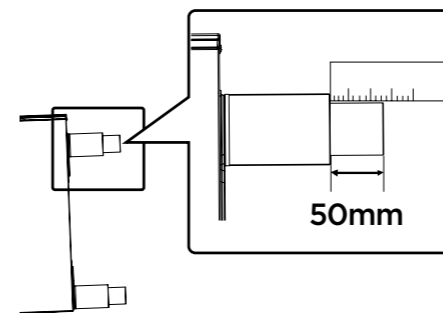

For a 900mm height kitchen bench top, adjust the lower half of the feet to measure 50mm as shown in the illustration.

Tilt the appliance upright by lifting the back of the hob and pivoting it about the back two feet.

#### **!** WARNING

Heavy item! This step must be performed by two persons.

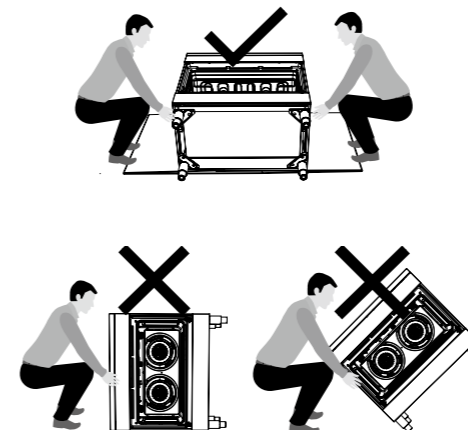

### Leveling oven

Place a level in the oven as below making sure the level sits on the front and rear forms. Adjust the feet accordingly to level the appliance.

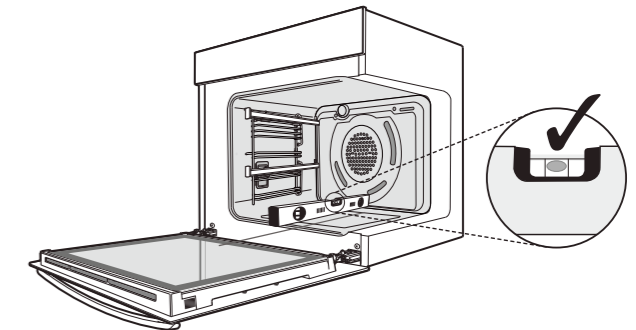

### Installing splashback

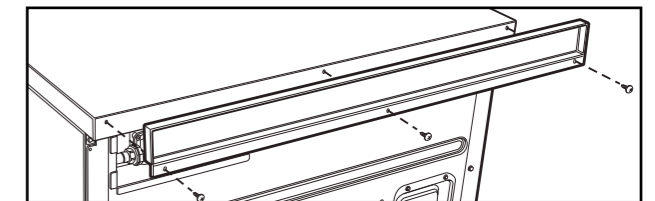

Fit splashback to rear of hob with three screws provided.

## INSTALLATION OF THE APPLIANCE (CONTINUED)

### Freestanding installation (continued)

#### Installation the anti-tilt brackets

To ensure cooker stability, the anti-tilt brackets must be installed.

There are left and right engagement slots for the anti-tilt bracket at the bottom rear of the appliance.

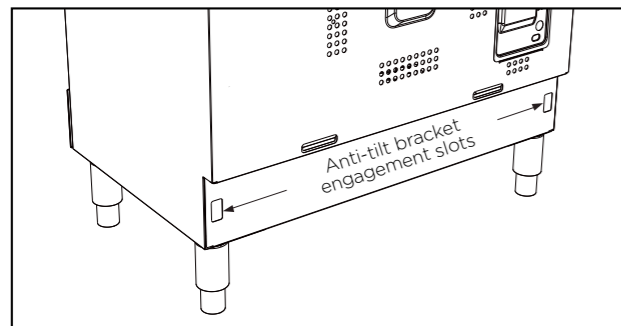

The following steps must be followed to ensure the correct installation of anti-tilt brackets and the stability of the appliances.

#### **!** CAUTION

It is not recommended to push and pull the appliance on uneven or rough surface. Use other means to maneuver the appliance if necessary.

1. Carefully push the appliance into the cabinet cavity until the back of the oven is flush against the back wall.
2. Use non-permanent methods to mark a line on the wall along the top surface of the splashback. This line is used as a reference line to locate the correct location of where the anti-tilt brackets need to be installed.
3. After the reference line is marked, pull the appliance out of the cabinet cavity to install the anti-tilt brackets.

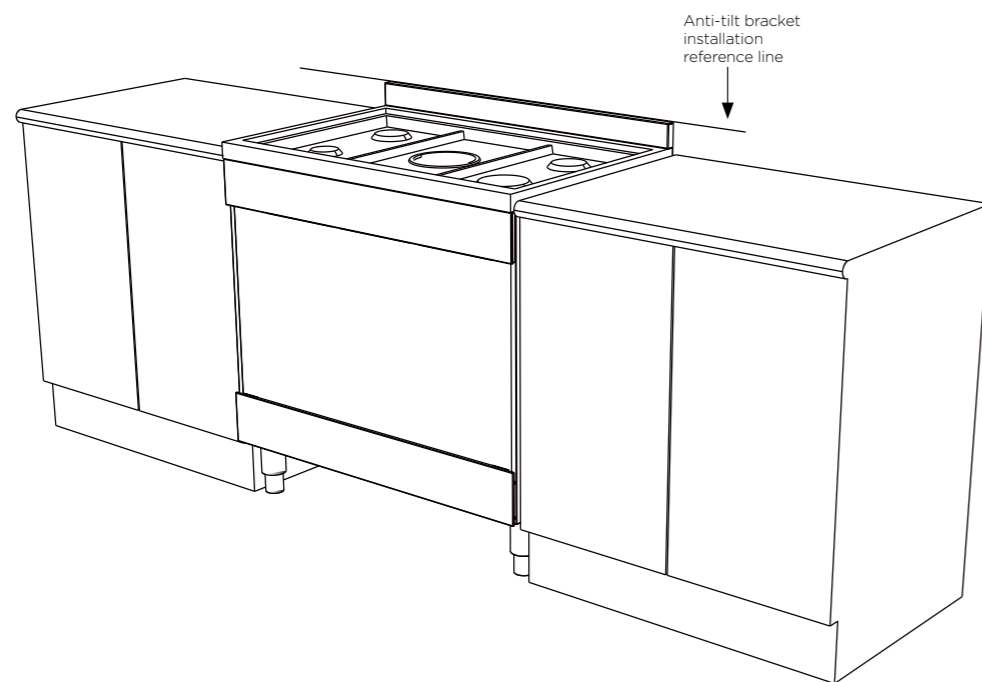

### Freestanding installation (continued)

#### **!** WARNING

- Appropriate fasteners must be used to suit the type of wall on which the anti-tilt brackets are installed.
  - Freestanding unit must be pushed up against the wall on installation. On gas units check that the gas hose, if used, has not been kinked during installation.
4. The anti-tilt brackets must be secured to the rear wall of the cavity with appropriate fasteners according to dimensions in diagram.

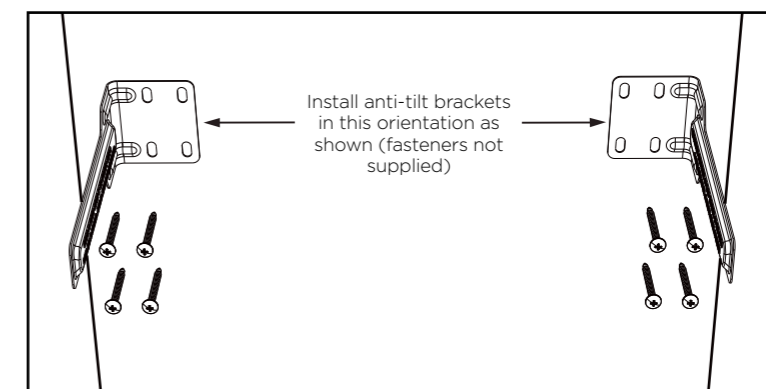
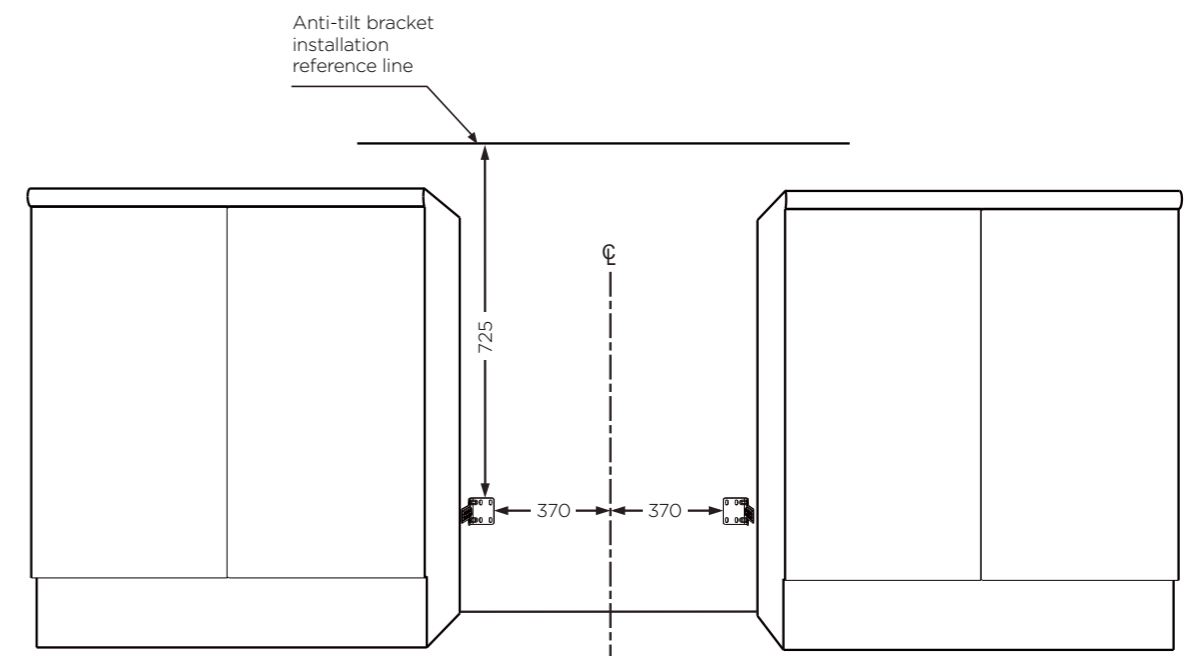

## INSTALLATION OF THE APPLIANCE (CONTINUED)

### Freestanding installation (continued)

- Connect services to the appliance prior to placing into cavity.
- To locate appliance, slide into cavity ensuring the anti-tilt brackets fully engaged with the rear left and right engagement slots.
- The unit must be pushed against the wall on installation.
- Re-install oven door, burner body, burner caps and trivets after the appliance is placed in the cavity.
- Gas only: check that the gas hose, if used, has not been kinked during installation.

### Installing the clip-on kick panel

Your cooker is supplied with a clip-on kick panel that can be assembled to clip onto the front feet for a more integrated and seamless kitchen appearance.

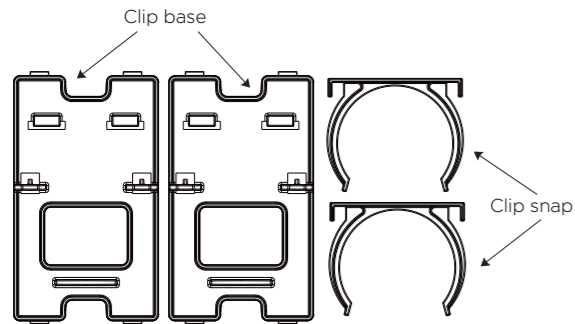

Assemble the clip snap onto the base.

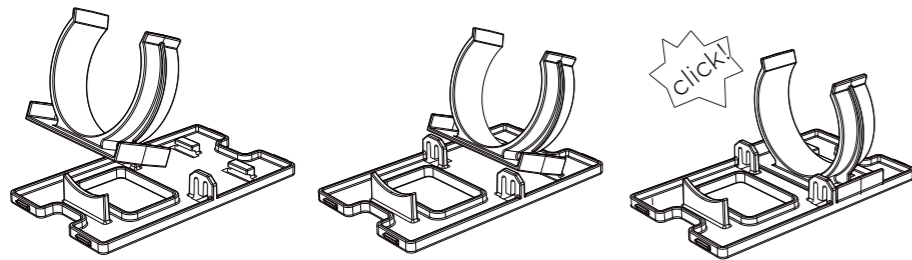

Press in both assembled clip modules into the kick panel in the orientation as shown below.

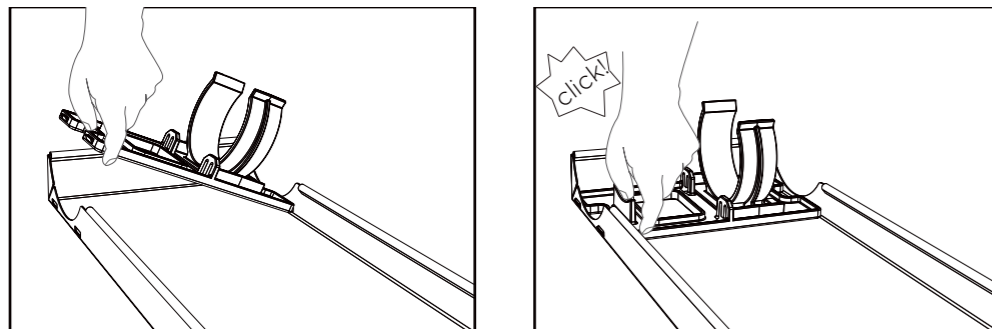

### Freestanding installation (continued)

Make sure both clip modules are in the same orientation after installation.

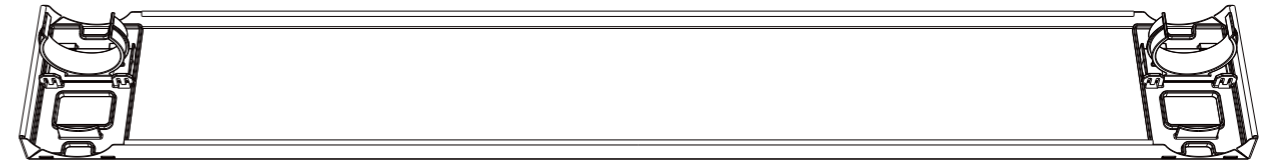

Clip the kick panel onto the front feet of the appliance. Make sure the kick panel snaps onto the larger section of the front feet.

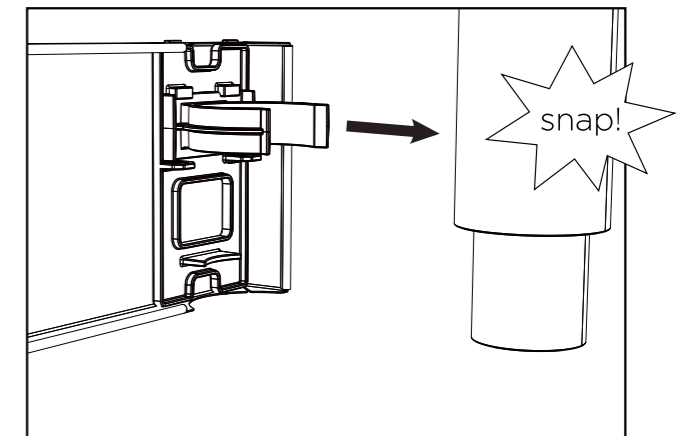
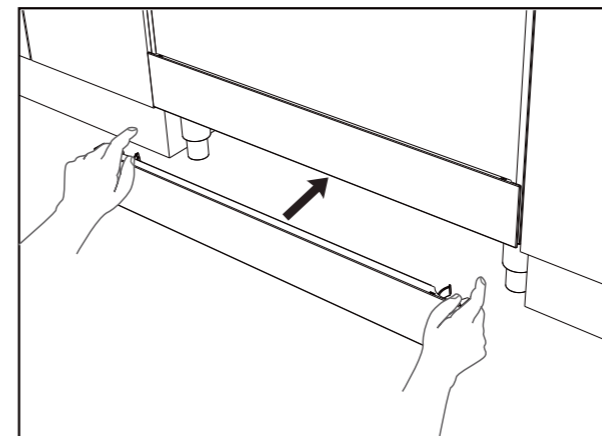

### Slot-in installation

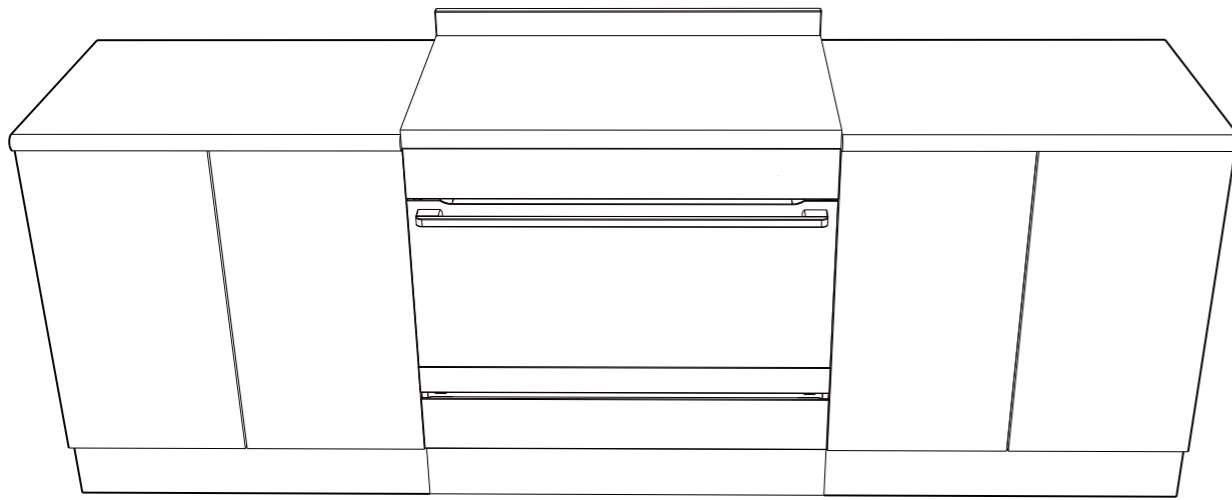

The slot-in type installation use the appliance as supplied. The appliance can be mounted on a plinth. This enables a continuous cupboard kickboard to be installed, giving a more integrated appearance. There is no clearance requirement between oven and adjacent side cabinets.

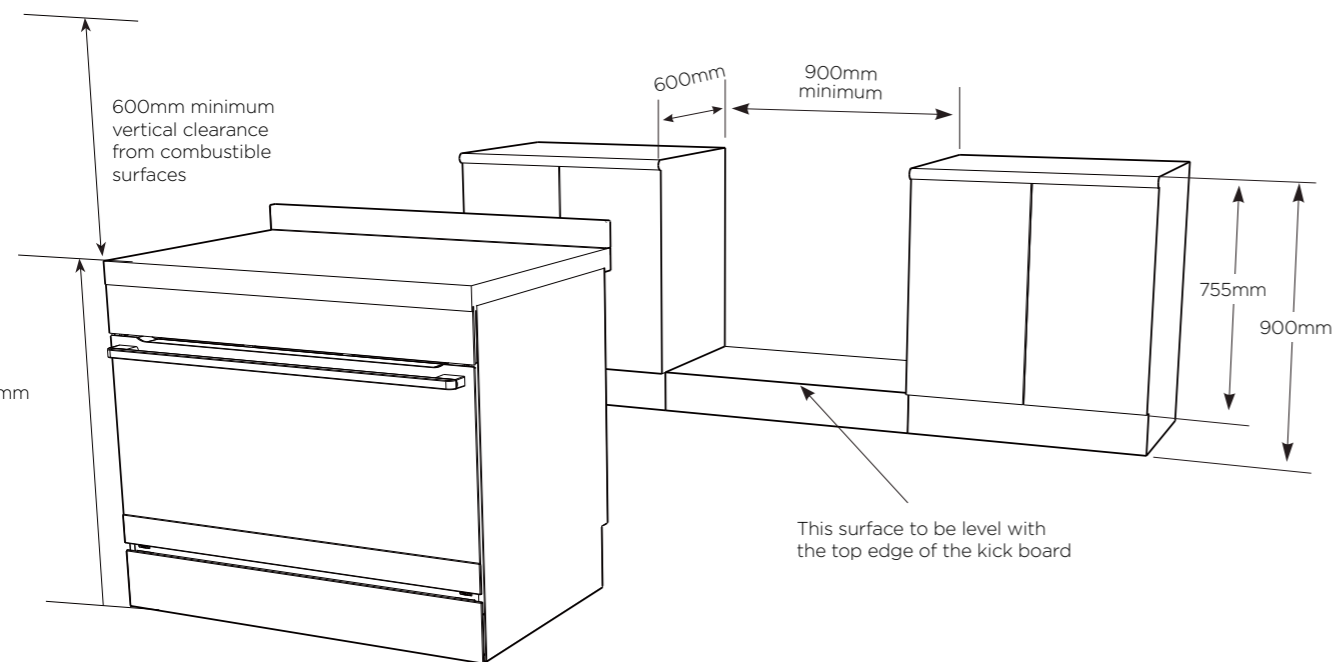

### INSTALLATION OF THE APPLIANCE (CONTINUED)

#### Slot-in installation (continued)

- The anti-tilt brackets are to be secured to the back wall with appropriate fasteners.
- Two stops are to be screwed to the plinth in locations as shown (stops provided). The stops locate into slots in the base of the appliance to prevent the product from being pulled forward when installed.
- Measurements from the rear wall are to be adjusted if there are tiles etc. that come between the appliance and the wall.
- Once services are connected, product can be lifted onto the plinth and pushed back carefully, ensuring the appliance engages into both brackets at the rear and the front stops.
- If the product requires removal for service, it must be lifted at the front approximately 5mm to clear the front stops prior to being pulled forward.

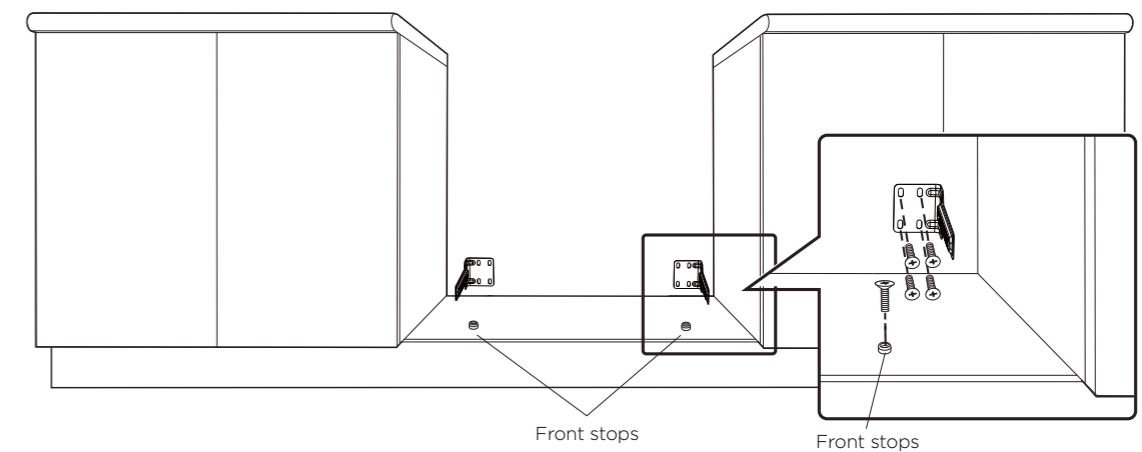
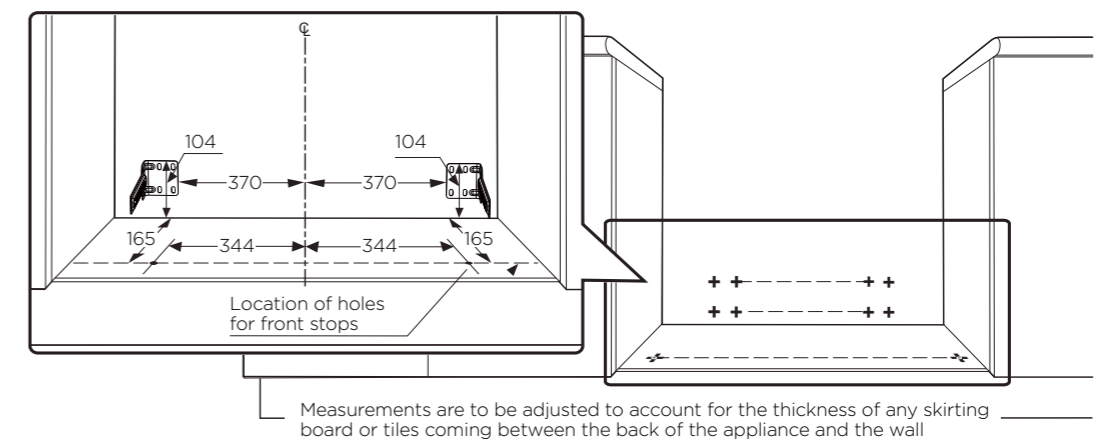

## WIRING REQUIREMENTS

The cooker MUST be installed in compliance with:

- Wiring connections in AS/NZS 3000 Wiring Rules.
- Local regulations, municipal building codes and other statutory regulations.

### For New Zealand Only:

The cooking range must be connected to the supply by a supply cord fitted with the appropriately rated plug that is compatible with the socket-outlet fitted to the final sub-circuit in the fixed wiring that is intended to supply this cooking range.

### Supply cord size required:

WFE9515SD - 2.5mm<sup>2</sup>

The Data plate gives information about rating and is located behind the bottom of the oven door.

- A functional switch MUST be provided near the appliance in an accessible position (AS/NZS 3000).
- Wiring MUST be protected against mechanical failure (AS/NZS 3000).
- Disconnection in the fixed wiring must occur in accordance with the AS/NZS 3000 wiring rules.
- The cooker MUST be properly earthed.
- This range must be connected with cable of 75°C rating minimum.
- This product has passed the insulation resistance test after manufacture. If the resistance reading is low at installation, it is probably caused by moisture from the atmosphere being absorbed by the elements after the range has been produced. (Pass at 0.01 MΩ as per AS/NZS 3000 - "Wiring Rules").

*Note: When connections are made to a multi-phase 230/240V supply, the bridge piece MUST be removed from between the active connections.*

### Rated power input

MODEL	TOTAL KW	A1 KW	A2 KW
WFE9515SD	4.5	4.5	-



### IMPORTANT

Before you cook in your new oven it is important that the protective oils used in the manufacture of the product be removed.

- Make sure that the room is well ventilated (to allow smoke to escape).
- Run the grill on high for 30 minutes without grill dish.
- Then run the oven on 180°C for 1 hour.

### Connecting to services and commissioning

This appliance must be installed by an authorised person, according to all codes and regulations of:

- Electrical supply authorities.
- Building regulations.
- Local government and council authorities.
- AS/NZS 5601.1.
- AS/NZS 3000.

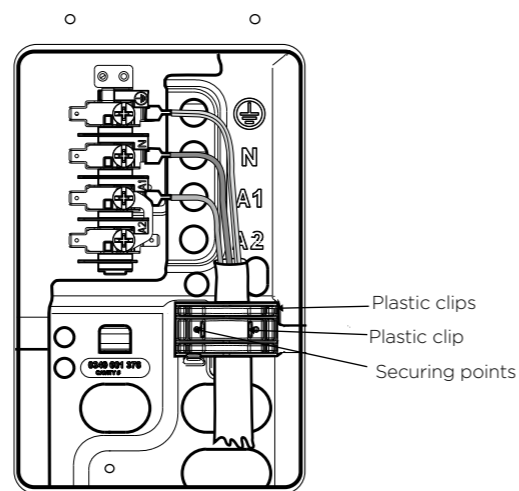

### Hard wiring detail

1. Remove terminal cover plate from rear panel of appliance.
2. Fit wires through hole in cover plate and make connections to terminals.
3. Engage wires into plastic clip. Secure plastic clip with two long silver screws (supplied in separate bag).
4. Replace cover plate onto rear panel.

## INSTALLING THE FREESTANDING COOKER

### Model WFE9515SD

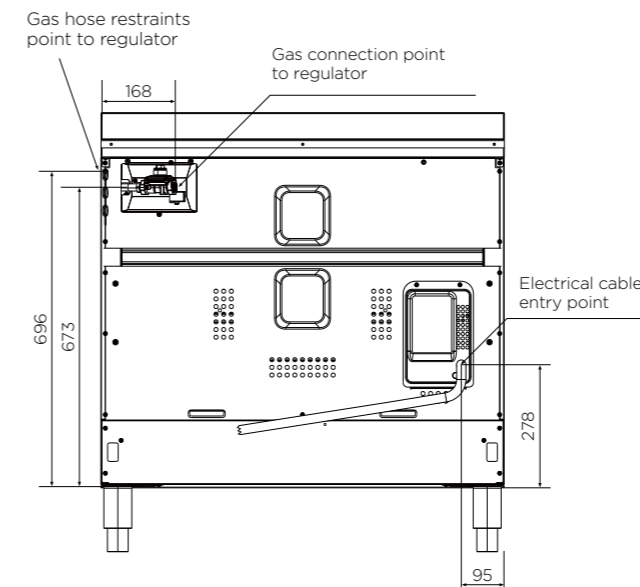

### Gas pressures

The following table shows the supply and operating pressures for various gases.

GAS TYPE	NATURAL GAS	UNIVERSAL LPG
Supply pressure at inlet to appliance regulator (if fitted)	1.13 (kPa) Minimum	2.75* (kPa)
Operating pressure at appliance test point	1.00 (kPa)	2.6 (kPa)

\*If the regulator is placed upstream of the cooker inlet, as is normal for cookers operating on LPG, then the supply pressure and operating pressure are the same.

### Injectors

The following table shows the injector sizes for each burner.

INJECTOR ORIFICE	NATURAL GAS	UNIVERSAL LPG
Low heat burner	1.00mm	0.55mm
Medium heat burner	1.35mm	0.70mm
High heat burner	1.60mm	0.90mm
Intense heat wok burner	1.75mm	1.00mm

### Checking piping size

To work out a suitable pipe size for connection use the information in this table.

GAS TYPE	NATURAL GAS	UNIVERSAL LPG
WFE9515SD	54.2MJ/h	45.5MJ/h

For information and requirements about construction and capacity of consumer piping refer to AS/NZS 5601 series of standards.

### Gas connection

Read these points before connecting to the gas supply:

- The appliance is preset for natural gas use, if LPG is to be used see Conversion to LPG section.
- Gas installation must be made in accordance with AS/NZS 5601.1, the local gas fitting regulations, municipal codes and other statutory regulations.
- The gas connection point is a ½" BSP external thread located at the rear of the appliance as shown.
- The regulator is to be fitted to the manifold inlet at the rear of the appliance and the connection is sealed using a tape or jointing compound suitable for gas connections. The consumer piping is then connected to the inlet of the regulator, either
  1. directly, or
  2. using a hose assembly and in accordance with AS/NZS 5601.1 (High level connection) together with the supplied elbow. The elbow is fitted to the inlet of the regulator and oriented to allow the hose to hang downward. The connection thread between the regulator and elbow is sealed using a tape or jointing compound suitable for gas connections.

This appliance is supplied set up for Natural Gas usage.

## LPG CONVERSION GAS COOKTOP

A conversion kit is included with the product for Universal LPG usage. The conversion kit contains 5 or 7 injectors (refer to LPG conversion table) and 1 LPG sticker.

Please follow the procedure below if a conversion to suit UNIVERSAL LPG is required:

1. Remove the hotplate trivets, burner caps and burner crowns to access the hotplate injectors. Replace the factory fitted injectors with the appropriate injectors, as supplied. Refer to injector orifice table for injector sizes. The injector size is stamped on the side of the injector.
2. Unscrew the top hat nut from the regulator. The top hat nut and control pressure spring assembly will disengage as an assembly.
3. Unscrew the threaded pin from top hat.
4. Upright threaded pin, so spring is free and screw pin back into the top hat until firm.
5. Refit the top hat nut assembly to the regulator ensuring that it is fully screwed down. The regulator is now set for connection to LPG.
6. Turn on the gas supply and at each new connection check for leaks using soapy water. Each hotplate valve should be turned on, one at a time, and the injector hole blanked off for several seconds.
7. The operation of the regulator can be confirmed by connecting a manometer to the pressure test point located on the side of the regulator body adjacent to the outlet.

With the appliance operating check the outlet pressure:

- when all burners of the appliance are operating at maximum,
- when the smallest burner of the appliance is operating at minimum.

Under these conditions the outlet pressure should not vary from the nominal outlet pressure of 2.60kPa by more than  $\pm 0.52\text{kPa}$ .

8. If the regulator appears to not be performing satisfactorily then check the following points:
  - If the outlet pressure is consistently too low then the inlet pressure may be too low and adjustment of an upstream regulator may be needed, or an upstream regulator or valve with insufficient flow capacity may be present in the gas supply line. If this is suspected then it may be necessary to repeat the checks whilst measuring both the inlet and outlet pressure to determine if the inlet pressure is in the range 2.75 – 7.00kPa.
  - Check that the insert has been fitted correctly.
  - Check that the turret screw is fully screwed down.
  - Check that the regulator has been fitted to the gas supply line in the correct orientation, the arrow on the base of the body indicates the direction of gas flow.

Once these checks have been completed, if the regulator still fails to perform in a satisfactory manner it should be replaced.

9. One by one, turn the knobs to minimum and screw in the bypass screw (accessible when the knob is removed) until a small stable flame results. Turn the knob to maximum and then back to minimum to ensure that the correct minimum flame is maintained.

10. Attach the LPG sticker to the cooker, near the gas supply inlet. Cover the Natural Gas label that is factory fitted.

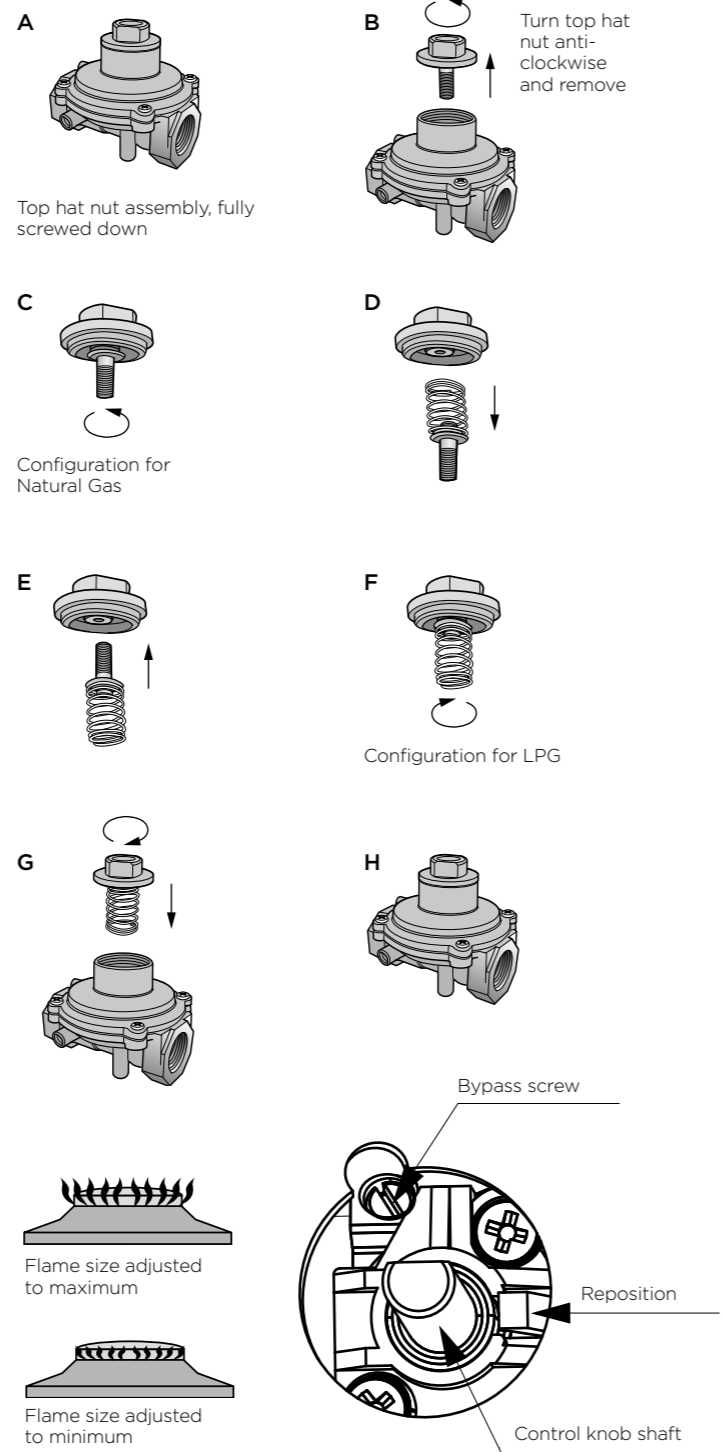

**NOTE:** You **MUST** test the cooker after installation, before you hand it over to the customer. You **MUST** have a manometer and a connecting tube.

## TESTING THE OPERATION OF THE GAS COOKER

### Checking gas supply

1. Check the manometer zero point is correct.
2. Connect the manometer to the cooker pressure test point. This is located on the regulator or LPG inlet fitting.
3. Turn on the gas supply and the electricity and try to ignite the gas.

**NOTE:** It will take additional time to light the gas for the first time as air needs to be purged from the pipes.

4. Check the operating pressure for the particular gas type.

### Checking the function of the regulator

With the appliance operating check the outlet pressure:

- when all burners of the appliance are operating at maximum,
- when the smallest burner of the appliance is operating at minimum.

Under these conditions the outlet pressure should not vary from the nominal outlet pressure by more than  $\pm 20\%$  of the nominal outlet pressure (ie  $\pm 0.20\text{kPa}$  for Natural Gas).

If the regulator appears to not be performing satisfactorily then check the following points.

1. If the outlet pressure is consistently too low then the inlet pressure may be too low and adjustment of an upstream regulator may be needed, or an upstream regulator or valve with insufficient flow capacity may be present in the gas supply line. If this is suspected then it may be necessary to repeat the checks whilst measuring both the inlet and outlet pressure to determine if the inlet pressure is in the range 1.13 – 5kPa.
2. Check that the regulator has been fitted to the gas supply line in the correct orientation, the arrow on the base of the body indicates the direction of gas flow.

Once these checks have been completed, if the regulator still fails to perform in a satisfactory manner it should be replaced.

### Testing the cooker features

- Observe the flame appearance on each burner. If it is much smaller or larger than expected, then the injector size needs checking.

**NOTE:** When flame is unsatisfactory, then refer to the Electrolux Technical Publications and correct the fault, if possible.

When maximum flame appearance is correct, then check the turn-down setting on each burner. If the settings appear to be incorrect, proceed as follows:

1. Adjust the bypass screw mounted on the body of each hotplate control cock. This is accessible when the control knob and the control panel are removed.
2. Check the ignition on all burners both separately and in combination.
3. Check the operation of the electrical components, if applicable.
4. If you are satisfied that the cooker is operating correctly, then turn it off and show the customer how to use it. Make sure you ask the customer to operate the clock and controls.

**NOTE:** If the cooker cannot be adjusted to perform correctly, then inform the customer of the problem and put a warning notice on the cooker. If the problem is dangerous, then disconnect the cooker. If there is a fault, then the customer should be advised to contact the manufacturer's local service organisation or the retailer.

## BEFORE OPERATING YOUR APPLIANCE FOR THE FIRST TIME

### Preparing your appliance for the first time

- Please remove all internal boxes and bags from the oven before operation.
- Please wipe out the oven interior prior to operation with warm soapy water and polish dry with a soft clean cloth. Do not close the oven door until the oven is completely dry.
- New appliances can have an odour during first operation. It is recommended to 'run in' your oven before you cook for the first time. Run the oven at 180°C for 2 hours and ensure that the room is well ventilated.
- DO NOT line the oven with foil, it will damage the enamel.
- Prior to installing accessories, remove all packaging and remove plastic film from external panels.

### Setting the time

If you have purchased a model fitted with an electronic or programmable timer, you must set the time of day before you can operate your appliance.

After electrically connecting the appliance, you must set the time of the day before you can operate your oven.

### Touch control electronic clock

1. After the appliance has been electrically connected, clock icon will flash.
2. To set the time of day, press or . 5 seconds after the last change, the "clock" indicator will disappear, confirming the time has been set.

*Note: The clock has a 24-hour display.*



## INSTALLING YOUR OVEN ACCESSORIES

### Slides (telescopic runners)

1. The selected models are supplied with a set of slides and instructions on how to assemble. Ensure the rack and slides are of the same hand. E.g. left hand slide should be fitted on the left hand rack.
2. The instructions also show recommended slide positions on the rack.

### Installing the slides (telescopic runners)

1. Obtain left hand side rack and left hand slide - see image to identify.

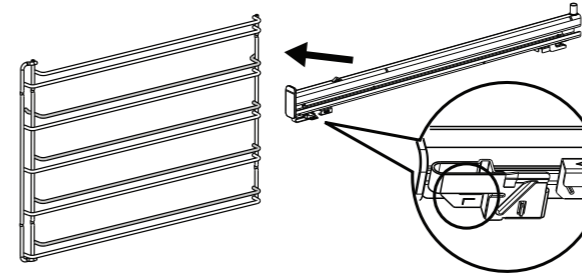

2. The shaded wires indicate the wire the slide can be mounted on. Fit slide rear clips to the rear of wire at an angle as shown below.

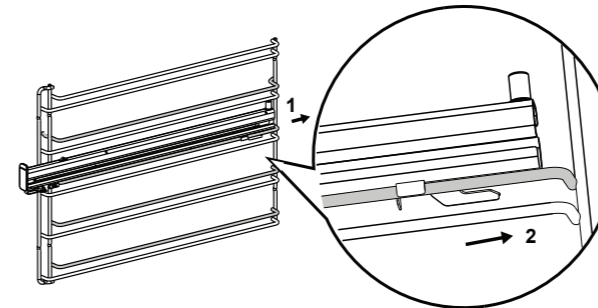

3. Push slide front clip over wire until secured

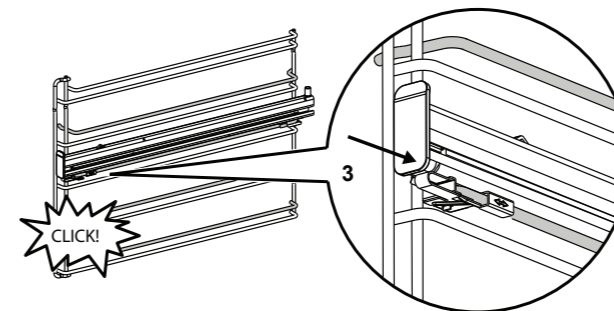

### Installing the side racks

1. Insert the rear peg into the rear access hole provided, ensuring peg is fully inserted.
2. Then locate the front peg into the front access hole and push in firmly.

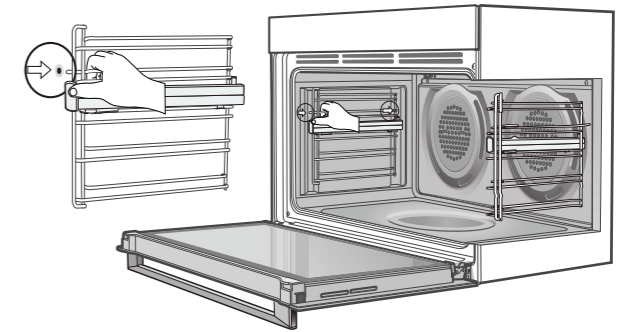

### Fitting grill dish and insert

Your oven comes with a full width grill dish and a grill insert. The grill dish insert is designed with flexibility to adjust distance between the food and the grill element.

### Maximum grill power

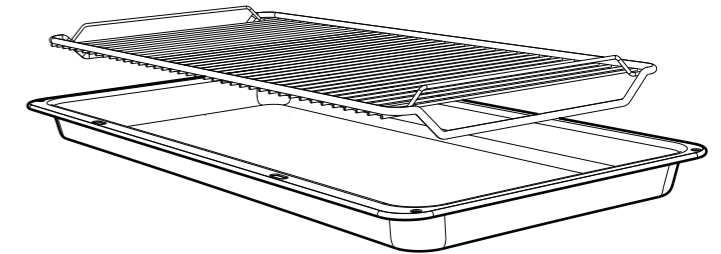

Grill dish insert brings the food closer to the grill element. Suitable when maximum grill power is needed.

### Moderate grill power

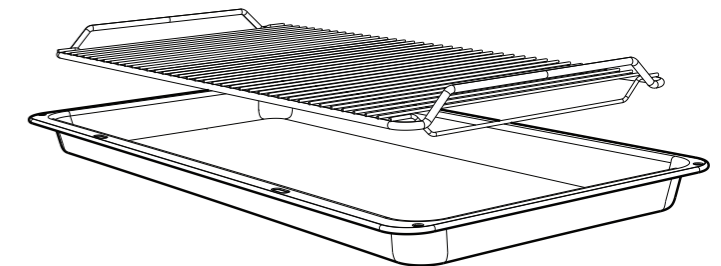

Food sits further away from the grill element. Suitable when moderate grill power is needed.

## INSTALLING BURNERS AND TRIVETS

### Installing burners

The burner crown must be fitted correctly into the burner cup or damage will occur during operation.

- To do this, ensure that the 2 ribs on either side of the spark plug hole are positioned into the 2 slots on the burner cup.
- The burner cap and burner crown must be clean and located correctly for the burner to light.

*NOTE: When the burner is correctly fitted it will sit level on the hob.*

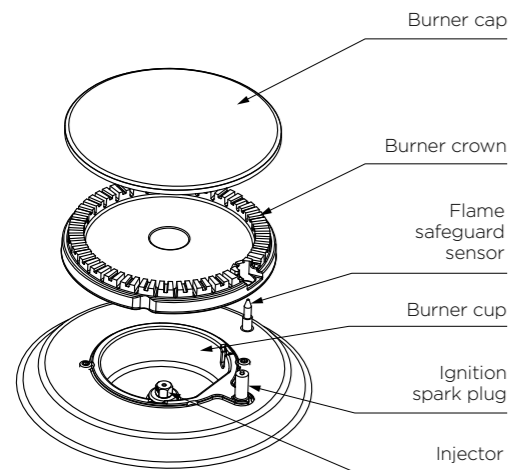

### Installing trivets

- The rubber feet on the trivets locate into the contours of the hob.
- Take care when placing the trivets as dropping them may damage the hob or trivet.

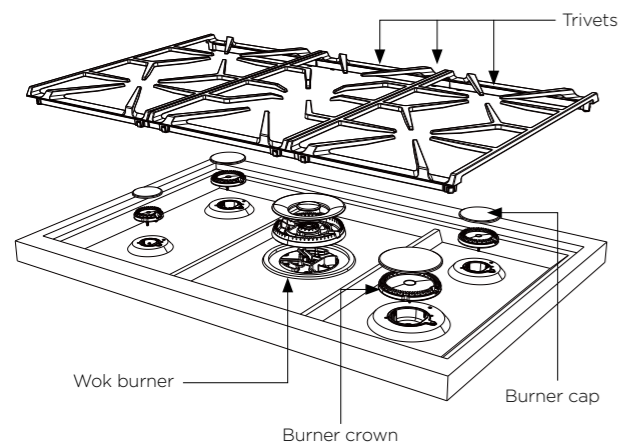

### Trivet installation sequence

Install the middle trivet first by aligning the trivet with the wok burner and gently placing the trivet on hob.

The middle trivet is designed to guide the location of the side trivets. Gently place the side trivets in the orientation shown.

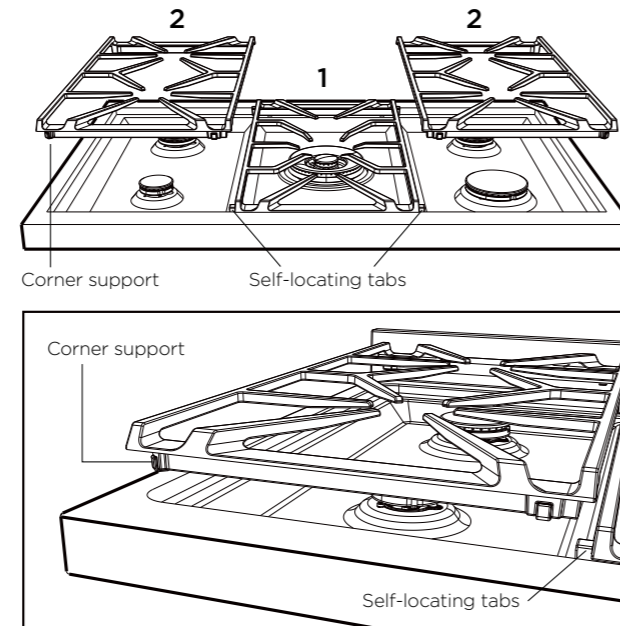

### Flame safeguard

Models with flame safeguard require the knob to continue to be depressed after flame is established for approximately 5 seconds. If the flame goes out when the knob is released, simply depress the knob again, this time holding it down with slightly more force for the same length of time.

#### **WARNING**

- Keep hands clear of burners when lighting.
- If burner does not light within 5 seconds, turn knob to 'Off' position, allow gas to disperse, then try lighting again.
- Burners **MUST** be operated between 'HIGH' and 'LOW' settings only.

#### **ENVIRONMENT**

To conserve gas, place the pan centrally over the burner and adjust the flame so that it does not go past the edge of the cookware.

*NOTE: In the absence of electrical power, carry out the ignition directly to the burner with a hand held ignition source.*

## GETTING TO KNOW YOUR COOKTOP

### Model WFE9515SD

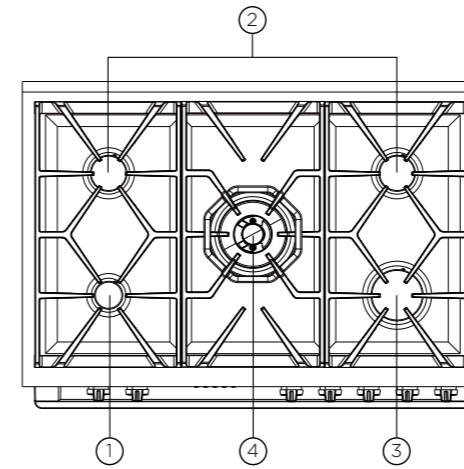

- 1. Low heat burner (5.1MJ/h)**  
Used for simmering with small cookware items.
- 2. Medium heat burner (9.0MJ/h)**  
Used for normal cooking and simmering with mid size cookware items.
- 3. High heat burner (12.1MJ/h)**  
Used for fast heating with large size cookware items.
- 4. Intense heat wok burner (19.0MJ/h)**  
Used for very fast heating with woks and other large size cookware items.

### Using your gas hot plates

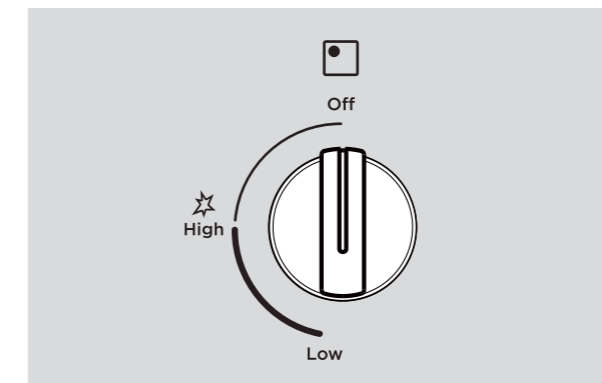

To light a burner with this knob, firstly depress and turn anti-clockwise to the 'High' flame position. The knob may be released once the flame is established and turned further anti-clockwise to reduce the flame height as desired.

Note 1: Gas control has limited movement.

Note 2: If the flame goes out when either knob is released, simply depress the knob again, this time holding it down for approximately 5 seconds.

## USING YOUR OVEN

### Understanding your oven functions

#### Rapid Heat

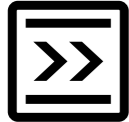

This function can be used for a quicker pre-heat of your oven. Heat comes from the elements surrounding the fans as well as the smaller element above the food. This will heat up your oven 30% faster.

#### Fan Bake



Heat comes from the elements surrounding the fans. The fans circulate the hot air around the oven cavity so that you can put your food in different places in the oven and still cook them at the same time. You can use the "Fan Bake" function for multi-shelf cooking, reheating cooked foods, pastries and complete oven meals. It will cook at a lower temperature and be faster than baking. Please note that some variation in browning is normal.

#### EasyBake +Steam



"EasyBake +Steam" adds humidity at the beginning of the baking process. In bakery products, this allows the dough to rise and helps create a moist interior while obtaining a golden and crispy crust. Before preheating, when the oven is cold, add water to the cavity well. Refer to chapter "EasyBake +Steam" for more details. For best results preheat the empty oven for 10 minutes prior to inserting food.

#### Bake/Pizza



"Pizza" is a combination of "Base heat" and "Fan bake" and offers you the combined benefits of both functions. Heat comes from the element surrounding the fan as well as the clean heat element below the oven floor. The "Pizza" function is ideal for foods that require cooking and browning on the base. It is great for foods such as pizzas, quiches, meat pies and fruit pies. Simply place the food in the middle of the oven and set the desired temperature.

#### Base Heat



Heat comes from the element below the floor of the oven. The Element is controlled by the thermostat and will turn on and off to maintain the set temperature. The "Base Heat" function can be used to add extra browning to the bases of pizzas, pies and pastries. Cook in the lower half of the oven when you are using only one shelf. For best results, use silver or shiny trays.

#### Defrost



The "Defrost" function uses low temperature air that is circulated by the fans. You can defrost (thaw) your food before you cook it. You can also use "Defrost" to raise your yeast dough and to dry fruit, vegetables and herbs.

#### Fan & Grill



"Fan Grill" offers you the benefits of both "Bake" and traditional "Grill" functions. The grill element turns on and off to maintain the set temperature while the fans circulate the heated air. The oven door remains closed for fan grill. You can use "Fan Grill" for large cuts of meat to give you a result that is similar to "rotisserie" cooked meat. Put your food on a shelf in the second lowest shelf position. Put the grill dish on the lowest shelf position to catch any spills. When using "Fan Grill" it is not necessary to turn the food over during the cooking cycle. Set the temperature to 180°C.

#### Grill



The "Grill" directs radiant heat from the powerful upper element onto the food. You can use the "Grill" function for tender cuts of meat, steak, chops, sausages, fish, cheese toasties and other quick cooking foods. Grill with the oven door closed. Preheat your grill for 3 minutes to get the best results. This will help seal in the natural juices of steak, chops etc. for a better flavour. You can slide your grill dish into either of the 2 spaces within the upper pairs of support rails.

#### Maxi Grill



"Maxi Grill" directs radiant heat from 2 powerful upper elements onto the food. You can use the "Maxi Grill" function for tender cuts of meat, steak, chops, sausages, fish, cheese toasties and other quick cooking foods. Grill with the oven door closed. "Maxi Grill" allows you to take full advantage of the large grill dish area and will cook faster than normal "Grill". For best results it is recommended to preheat your grill for 3 minutes. This will help seal in the natural juices of steak, chops etc. for a better flavour. You can slide your grill dish into either of the 2 spaces within the upper pairs of support rails.

#### Cooling/Venting fan

Your built-in appliance is fitted with a cooling fan. This prevents your kitchen cabinet from overheating and reduces the condensation inside the oven. It will operate whenever you are using your oven or grill and will blow warm air across the top of the oven door. In some appliances the cooling fan may continue to operate after the appliance is turned off. It will switch off by itself once oven is cool.

#### Condensation

Excess condensation may fog the oven door. This may happen when you are cooking large quantities of food from a cold start. You can minimise condensation by:

- Keeping the amount of water used whilst cooking to a minimum.
- Making sure that the oven door is firmly closed.
- Baking custard in a baking dish that is slightly smaller than the water container.
- Cooking casseroles with the lid on.

*NOTE: If you are using water in cooking, this will turn to steam and may condense outside your appliance. This is not a problem or fault with your oven.*

#### OPERATING SEQUENCE

Select the oven function

Turn the oven function selector clockwise to select the desired oven function.

*NOTE: each oven function has a default temperature which can then be adjusted as outlined below.*

#### Preheating your oven with "Rapid Heat"

To preheat your oven select the "Rapid Heat" function. This function allows your oven to reach the preset temperature quicker than any other cooking function.

1. Turn the function selector to "Rapid Heat".
2. Set the desired preheat temperature, by rotating your oven temperature selector. When the indicator light above the temperature selector goes out, the oven has reached the desired temperature. Select the oven function you require for cooking or baking and place the food in the oven.

#### On completion of cooking

- The heat source will turn off, the timer will beep and the end time and/or cook time 'indicators' will flash.
- Even though the heating element turns off the oven will still retain substantial heat. This will continue to cook the food until it is removed or the oven cools down. If you do not plan on being present when the oven turns off, you should take this extra heating time into account.
- Turn the function and temperature controls to the off position.
- Press any button to stop the timer beeping.

#### Operating the touch control clock models

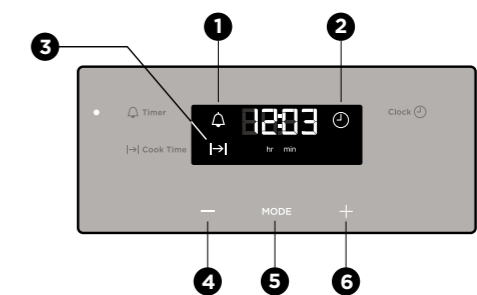

1. On when timer is set
2. Time of day icon
3. Cook time icon
4. Minus
5. Touch to toggle through timer modes
6. Plus

## USING YOUR OVEN (CONTINUED)

### Setting the time of day

Before the appliance can be used, the time must be set.

After the appliance has been electrically connected, clock icon will flash.

To set the time of day in hours and minutes touch the — or + symbols. Refer to the diagram above.

5 seconds after the last change, the clock icon will disappear, confirming the time has been set. Once the time has been entered, the clock advances minute by minute.

*NOTE: The clock has a 24 hour display.*

### Change the time of day (Daylight saving)

1. Press **MODE** until the clock icon begins flashing.
2. Press — or + to change the time. 5 seconds after the last change, the clock icon will disappear, confirming the time has been set.

### Setting the timer

1. Touch the **MODE** symbol until the timer icon begins flashing.
2. Set the countdown time you want by using — and +. 5 seconds after the last change the timer icon will stop flashing and the countdown will start.
3. To stop the beeper, touch any symbol.

### Setting the cooking duration

1. Check the clock displays the correct time of day.
2. Select the desired oven function and temperature. The oven indicator light will glow and the heating source will come on.
3. Press **MODE** until the cook time icon begins flashing.
4. Set the cooking duration you want by using — or +. 5 seconds after the last change, the cook time icon will stop flashing.

*NOTE: Do not forget to add preheating time if necessary.*

### To check or cancel settings

1. To check settings, touch the **MODE** symbol until the desired setting is displayed. The relevant icon will flash.
2. To cancel 'delayed start' touch the **MODE** symbol until the end time icon flashes. Touch and hold the — symbol until the clock no longer reverses (a beep will be heard). If temperature and function knobs are still at a setting, the oven will start once the end time icon stops flashing.
3. To cancel 'auto shut off', touch the **MODE** symbol until the cook time icon flashes. Touch and hold the — symbol until the clock no longer reverses (at 0:00 a beep will be heard). This automatically cancels 'auto shut off'. If the temperature and function knobs are still at a setting, the oven will start once the cook time icon stops flashing. Because 'auto off' is cancelled the oven will continue to heat until it is manually turned off.

### On completion of cooking

The oven will turn off, the timer will beep and the end and cook time icons will flash.

1. Turn the function and temperature controls to the off position.
2. Press any button to stop the timer from beeping.

## EASYBAKE+STEAM

Your oven has the ability to add steam while baking. Cooking with steam is a great addition to straight 'hot air' cooking. Steam brings out all the natural flavours and goodness in the food, cooks evenly from surface to centre and retains more nutrients and vitamins. Steam assisted cooking consistently produces juicy, succulent interiors with crisp, golden exteriors.



### WARNING

Risk of burns and damage to the appliance.

- Do not open the appliance door when the steam function operates, with the exception of preheating.
- Open the appliance door with care after the steam function stops.
- Refer to cleaning the appliance for cleaning after the steam function operates.

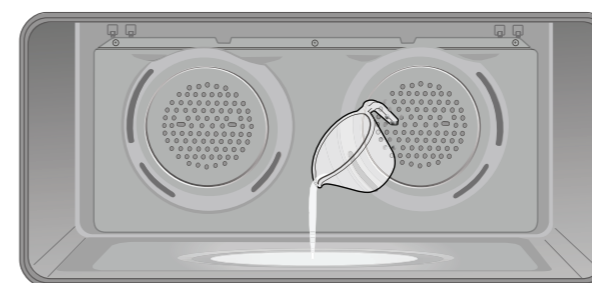

1. Open the oven door.
2. Fill the cavity well with 200ml of water (only when the oven is cold).
3. Set the 'EasyBake +Steam' function.
4. Set the temperature using the + and — symbols.
5. Preheat the oven for 10 minutes or according to the recipe suggestions.
6. Place food in the appliance and close the oven door.



### CAUTION

Do not refill the cavity well with water during cooking or when the oven is hot to avoid damage to enamel.



### WARNING

Make sure that the appliance is cool before you remove the remaining water from the cavity well.

## COOKING TEST

### Get to know your new oven with this 'Simple Test Cake'

Although we strive for a perfect performing oven, it's possible that there will be some variation in colour when baking. Therefore, we suggest this simple, easy and delicious to make Simple Test Cake, it can help you understand your new oven. All ovens do sometimes have hot or cold spots, therefore it is important to judge with your eye as you may require to rotate during baking.

#### 'Simple Test Cake'

125g butter, softened to room temperature  
 1 cup caster sugar  
 1 teaspoon pure vanilla essence  
 4 large eggs  
 2 cups self-raising flour  
 pinch of salt  
 4 tablespoons (80ml) full-cream milk

#### Method:

1. Butter base and sides of two 20cm straight-sided round or square cake pans. Then line the base with grease proof or baking paper.
2. Preheat oven to moderate '180°C' (170°C fan forced) and ensure oven shelf is in the centre position of oven.
3. Cream softened butter and sugar until light in colour.
4. Add vanilla essence.
5. Then eggs one at a time, beating well after each addition.
6. Sift flour and salt into the mixture and beat until well combined.
7. Add milk and beat or stir to combine.
8. Spoon mixture equally between prepared cake pans.
9. Bake in preheated oven, middle shelf for about 25 to 35 minutes or until when tested with a fine cake skewer it comes out clean, or the edges of the cakes have come away slightly from the sides of the cake pans.
10. Remove from oven to wire cake rack and rest for 5 minutes before removing from cake pans. Cool completely.

To Serve: sandwich together with your favourite jam or conserve, and dust top with pure icing sugar.

*NOTE: If desired substitute butter for either margarine or olive oil spread. Recipe is based on the Australian standard metric 250ml cup and 20ml tablespoon sets.*

- For best baking results preheat oven for 30 minutes.
- Select the correct shelf location for food being cooked.
- The grill tray can be used in the oven as a baking dish, except in oven shelf location 1.
- Make sure dishes will fit into the oven before you

switch it on.

- Keep edges of baking dishes at least 40mm from the side of the oven. This allows free circulation of heat and ensures even cooking.
- Do not open the oven door more than necessary.
- Do not place foods with a lot of liquid into the oven with other foods. This will cause food to steam and not brown.
- After the oven is turned off it retains the heat for some time. Use this heat to finish custards or to dry bread.
- Do not use a lot of cooking oil when roasting. This will prevent splattering oil on the sides of the oven and the oven door. Polyunsaturated fats can leave residue which is very difficult to remove.
- When cooking things which require a high heat from below (e.g. tarts), place the cooking dish on a scone tray in the desired shelf position.
- For sponges and cakes use aluminium, bright finished or non-stick utensils.
- Remove unnecessary trays or dishes when roasting or baking.

#### Oven shelf location

Your freestanding oven has 5 positions for mounting the shelves. These are numbered from 1 (the lowest shelf position) to 5 (the highest shelf position). See diagram.

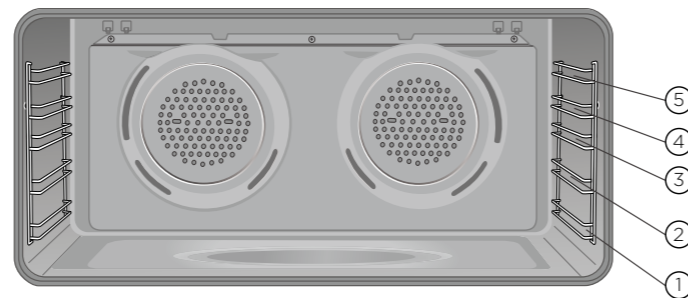

To give maximum space above and below the shelves, load them in this way:

- When cooking with 1 shelf, use position 2 or 3.
- When cooking with 2 shelves, use position 1 and 3.
- When grilling use position 4 or 5.

**NOTE:** Use the oven efficiently, by cooking many trays of food at the same time e.g. 2 trays of scones, small cakes or sausage rolls.

### (see also TROUBLESHOOTING)

PROBLEM	CAUSES	REMEDIES
Uneven cooking:	<ul style="list-style-type: none"> <li>• Incorrect shelf position.</li> <li>• Oven tray too large.</li> <li>• Trays not centralised.</li> <li>• Air flow in oven uneven.</li> <li>• Grill dish affecting thermostat.</li> </ul>	<ul style="list-style-type: none"> <li>- Select shelf that puts food in the centre of the oven.</li> <li>- Experiment with other trays or dishes.</li> <li>- Centre trays.</li> <li>- Rotate food during cooking.</li> <li>- Remove grill dish from oven on bake modes.</li> </ul>
Baked products too brown on top:	<ul style="list-style-type: none"> <li>• Oven not preheated.</li> <li>• Baking tins too large for the recipe.</li> <li>• Baking tins not evenly spaced.</li> <li>• Products not evenly sized or spaced on trays.</li> <li>• Baking temperature too high.</li> </ul>	<ul style="list-style-type: none"> <li>- Preheat the oven.</li> <li>- Use correct size tins.</li> <li>- Stagger baking tins at least 3cm between tins and the oven walls.</li> <li>- Make into same size and shape, &amp; spread evenly over trays.</li> <li>- Lower the temperature.</li> </ul>
Baked products too brown on bottom:	<ul style="list-style-type: none"> <li>• Baking tins too large for the recipe.</li> <li>• Baking tins are dark metal or glass.</li> <li>• Food too low in the oven.</li> <li>• Oven door opened too frequently during baking.</li> <li>• Baking temperature too high.</li> <li>• Grill dish affecting thermostat.</li> </ul>	<ul style="list-style-type: none"> <li>- Use correct size tins.</li> <li>- Change to shiny, light tins or lower the temperature by 10°C.</li> <li>- Cook one shelf higher.</li> <li>- Don't open the oven door until at least half the cooking time has passed.</li> <li>- Lower the temperature.</li> <li>- Remove grill dish from oven on bake modes.</li> </ul>
Cakes have a cracked, thick crust:	<ul style="list-style-type: none"> <li>• Baking temperature too high.</li> <li>• Food too high in oven.</li> <li>• Cake batter over mixed.</li> <li>• Pan too deep.</li> <li>• Baking pans dark.</li> </ul>	<ul style="list-style-type: none"> <li>- Lower the temperature.</li> <li>- Cook one shelf lower.</li> <li>- Mix just long enough to combine ingredients.</li> <li>- Check size of pan and use recommended size.</li> <li>- Change to shiny pans.</li> </ul>
Baked products are pale, flat and undercooked:	<ul style="list-style-type: none"> <li>• Baking temperature too low.</li> <li>• Food too low in oven.</li> <li>• Baking time too short.</li> <li>• Incorrect tin size.</li> </ul>	<ul style="list-style-type: none"> <li>- Raise the temperature.</li> <li>- Cook one shelf higher.</li> <li>- Increase cooking time.</li> <li>- Use correct size tin.</li> </ul>
Cakes fallen in the centre:	<ul style="list-style-type: none"> <li>• Baking temperature too low.</li> <li>• Baking time too short.</li> <li>• Proportions of ingredients incorrect in the recipe.</li> <li>• Opening door too early in baking.</li> </ul>	<ul style="list-style-type: none"> <li>- Raise the temperature.</li> <li>- Increase cooking time.</li> <li>- Check recipe.</li> <li>- Do not open the door until the last quarter of cooking time.</li> </ul>
Roast meat and potatoes not browning in fan oven:	<ul style="list-style-type: none"> <li>• Poor hot air circulation.</li> <li>• Grill dish affecting thermostat.</li> </ul>	<ul style="list-style-type: none"> <li>- Elevate food onto a rack to allow air circulation.</li> <li>- Remove grill dish from oven on bake modes.</li> </ul>
Juices running out of meat:		<ul style="list-style-type: none"> <li>- Do not pierce meat with fork, turn with tongs.</li> </ul>
Grilled meats overcooked on outside and raw in the centre:		<ul style="list-style-type: none"> <li>- Grill at lower insert position.</li> </ul>
Grilled chops and steaks curling:		<ul style="list-style-type: none"> <li>- Cut into fat every 2cm (1/2").</li> </ul>

# COOKING GUIDE

## Choosing the best oven settings

The following table is intended as a guide and experience may show some variation in cooking times necessary to meet individual requirements. We recommend that you preheat your oven for 30 minutes.

### Modes without Oven Fan

FOOD		TEMPERATURE °C	OVEN SHELF POSITION*	TIME IN MINUTES
Scones	Plain or fruit	220	2 or 3	10 - 15
Biscuits	Rolled	170	3	13 - 18
	Spooned	190	3	13 - 18
	Shortbread biscuits	160	3	30 - 35
Meringues	Hard - individual	110	3	90
	Soft - individual	180	3	15 - 20
	Pavlova - 6 egg	110	3	75
Cakes	Cupcakes	190	2 or 3	15 - 20
	Sponge - 4 egg	180	2 or 3	20 - 30
	Shallow butter cake	180	3	25 - 30
Pastry - short crust	Cornish pasties	200	3	40 - 45
	Custard tart	200/180	3	Pastry 8/200 Whole tart 10/200 & 20/180
Pastry - choux	Cream puffs	210	3	25 - 30
Yeast goods	Bread	210	3	25 - 30

### Modes with Oven Fan

FOOD		TEMPERATURE °C	OVEN SHELF POSITION*		TIME IN MINUTES
			SINGLE SHELF	MULTI SHELF	
Scones	Plain or fruit	210	2 or 3	1 & 3	10 - 15
Biscuits	Rolled	150	2 or 3	1 & 3	13 - 18
	Spooned	180	2 or 3	1 & 3	13 - 18
	Shortbread	150	2 or 3	1 & 3	13 - 18
Meringues	Hard - individual	100	2 or 3	1 & 3	90
	Soft - individual	165	2 or 3	1 & 3	15 - 20
	Pavlova - 6 egg	100	2 or 3	1 & 3	75
Cakes	Cupcakes	180	2 or 3	1 & 3	15 - 20
	Sponge - 4 egg	170	2 or 3	1 & 3	20 - 30
	Shallow butter cake	170	2 or 3	1 & 3	25 - 30
	Rich fruit cake	170	2 or 3	1 & 3	60
Pastry - short crust	Cornish pasties	180	2 or 3	1 & 3	40 - 45
	Custard tart	190/170	2 or 3	1 & 3	20 - 30
	Whole tart				Pastry 8/190 Whole tart 10/190 & 20/170
Pastry - choux	Cream puffs	200	2 or 3	1 & 3	25 - 30
Yeast goods	Bread	200	3	1 & 3	25 - 30

\* Counting from the bottom shelf up. Oven shelf location

## EasyBake +Steam function

FOOD		WATER IN CAVITY WELL (ML)	TEMPERATURE °C	OVEN SHELF POSITION*	TIME IN MINUTES
Yeast goods	Bread loaves	200	180 - 200	2 or 3	35 - 45
	Bread rolls	200	190 - 210	2 or 3	20 - 25
	Gluten free bread	200	180 - 200	2 or 3	40 - 50
	Pizza (fresh)	200	210 - 220	2 or 3	15 - 20
	Focaccia	200	160 - 170	2 or 3	20 - 30
Biscuits	Rolled	200	160 - 170	2 or 3	10 - 15
	Spooned	200	160 - 170	2 or 3	10 - 15
Scones	Plain or fruit	200	200 - 210	2 or 3	10 - 15
Cake	Cupcakes	200	180	2 or 3	20 - 25
	Sponge - 4 eggs	200	170	2 or 3	20 - 30
	Shallow butter cake	200	170	2 or 3	25 - 30
Pastry - choux	Cream puffs	200	200	2 or 3	20 - 30
Puff pastry		200	200	2 or 3	15 - 20
Frozen croissants		200	170 - 180	2 or 3	15 - 25

\* Counting from the bottom shelf up.

## Grilling Guide



### WARNING

Always clean the grill/oven dish after every use. Excessive fat build up may cause a fire.

### Grilling is conducted with the oven door closed

As a method of cooking, grilling can be used to:

- Enhance the flavours of vegetables, fish, poultry and meat.
- Seal the surface of the food and retain the natural juices.

This table shows how to grill different types of meat:

Beef	Tenderloin, rump, sirloin. Brush with oil or melted butter, especially if the meat is very lean.
Lamb	Loin chops, short loin chops, chump chops, and forequarter chops. Remove skin or cut at intervals to stop curling. Brush with oil or melted butter.
Sausages	Prick sausages to stop skin from bursting.
Poultry	Divide into serving pieces. Brush with oil.
Fish	Brush with oil or melted butter and lemon juice.
Bacon	Remove rind. Grill flat.

### Guide to better grilling

Steak	15 - 20 minutes
Chops	20 - 30 minutes

Fish	8 - 10 minutes
Bacon	4 - 5 minutes

No definite times can be given for grilling because this depends on your own tastes and the size of the food. These times should only be used as a guide and remember to turn the food over halfway through the cooking process.

For better grilling results, follow these easy instructions:

- Preheat grill for at least 3 minutes.
- Choose only prime cuts of meat or fish. If the cut is less than 5mm thick it will dry out. If the cut is more than 40mm thick, the outside may burn whilst the inside remains raw.
- Do not place aluminium foil under the food as this prevents fats and oils from draining away, which could result in a fire.
- Baste the food during cooking with butter, olive oil or marinade. Grilled food is better if marinated before cooking.
- Use tongs to turn food as a fork pierces the surface and will let juices escape.

### Fan & Grill

The "Fan & Grill" assists the grilling process by circulating the heat evenly around the food. The recommended temperature setting is 180°C for all fan grilling functions.

- Place the grill dish on the bottom rack.
- Place meat/poultry on an oven shelf above the grill dish.

**WIPE OFF ANY OIL OR FAT WHICH SPATTERS WHILE THE OVEN IS STILL WARM.**

## COOKING GUIDE (CONTINUED)

### WARNING

- Always make sure that the oven is electrically isolated before cleaning. This can be done by the functional switch nearby.
- Do not line the bottom of the oven with foil or cookware.
- Do not use steam cleaners.

### Stainless steel

### WARNING

- The oven door trim, the control panel and the storage compartment are decorated with a special stainless steel that resists finger marks and should only be cleaned with warm water and a mild detergent. Do not use stainless steel cleaners, abrasive cleaners or harsh solvents on these parts.

*NOTE: Make sure you follow the polish or brushing lines in the stainless steel.*

- All grades of stainless steel can stain, discolour or become greasy. You must clean these regularly by following the procedures below if you want your appliance to look its best, perform well and have a long life.
- Care must be taken when wiping exposed stainless steel edges, they can be sharp!
- The stainless steel gas hob can be cleaned with stainless steel cleaners if it becomes soiled or discoloured.
- A suitable cleaner can be purchased from Electrolux Customer Care Centres.

### Glass

- Glass surfaces on doors and control panels are best cleaned immediately after soiling.
- A damp cloth may help remove baked on food deposits.

### WARNING

- The door glass on this appliance is made from a tough, durable material that withstands heating and cooling without breaking. However, it must be remembered that it is GLASS, it may break. Treat it accordingly! Should you have any questions about the glass in your new appliance, please contact the customer care centre by dialling 13 13 49.
- Do not use harsh abrasive cleaners or sharp metal scrapers to clean the oven door since they can scratch the surface, which may result in the shattering of glass.

### Grill

- Always keep the grill dish and grill dish insert clean, as any fat deposits may catch fire.

### Gas hotplate

- The trivets can be removed for cleaning by carefully lifting them from the hob.
- Clean by washing with warm soapy water.
- The burner caps and crowns are also removable for cleaning.
- If the caps, crowns and cups are heavily soiled, use a non-abrasive cleaning compound.
- Flame port blockages should be removed by using a matchstick or brush.
- Do not clean them with abrasive or caustic type cleaners, or clean them in a dishwasher.

### Injector

- Ensure the injector remains free of any foreign material. If necessary, use a thin piece of wire to clear the orifice. Location of injector is shown on Section Installing Burners and Trivets.

### Oven

- Always keep your appliance clean. Ensure that fats and oils do not accumulate around elements, burners or fans.
- Always keep the oven dish, baking trays, grill dish and grill dish inserts clean, as any fat deposits may catch fire.
- Always wrap your meats in foil or an oven roasting bag to minimise cleaning. Any polyunsaturated fats can leave a varnish-like residue which is very difficult to remove.

### CAUTION

Ensure the appliance is off and cool before cleaning.

### Enamel (on burner skirts and trivets)

Persistent stains may require rubbing with a nylon scourer or creamed powder cleansers. Household enamel cleaners are available, follow the manufacturer's instructions in their use. **Harsh abrasive cleaners, powder cleaners, steel wool or wax polishes should not be used.**

### Stainless steel (Models with Stainless Steel hob)

Simply wipe with a soft cloth using warm water and a mild detergent and rinse with clean water. Where stainless steel has become extremely dirty or discoloured, use a stainless steel cleaner – but be sure to follow the brushing lines.

### Trivets and burners

These can all be lifted off and removed for separate cleaning.

*NOTE! When refitting the burners, ensure that they are correctly seated.*

Ensure burners are thoroughly dried after cleaning or spillage. When cleaning the burners, ensure that all the flame ports are free of any blockage (refer to Figure 1b on page 4). If necessary, use a toothpick or brush to clear ports. The outer surface of the burner caps have a polished finish and extra care needs to be taken to avoid scratching this surface during cleaning. In instances of heavy soiling, it may be necessary to apply a non-abrasive cleaning compound and rub with a cloth until the soiling is removed and then finish with a soft, dry cloth.

*NOTE! DO NOT place trivets or burners in the dishwasher.*

### Ignition spark plug and flame safeguard sensor

**GENTLY** clean the ignition spark plug and flame safeguard sensor with a damp cloth to avoid lighting difficulties.

Ensure that they are dry before use.

Remove deposits with a soft cloth and warm soapy water then wipe with a dry soft cloth. If there are signs of

## CLEANING YOUR OVEN ACCESSORIES

### Removing the trays and shelves from your appliance

- Slide the dish and grill tray towards you until they reach the front stop.
- Tilt them up at the front to clear the side supports, taking care not to spill the contents.
- Lift them clear.
- Wash the tray and shelves in hot soapy water.
- Reverse the above steps to put the grill tray and shelves back again.
- Ensure that they are placed between the 2 support wires.

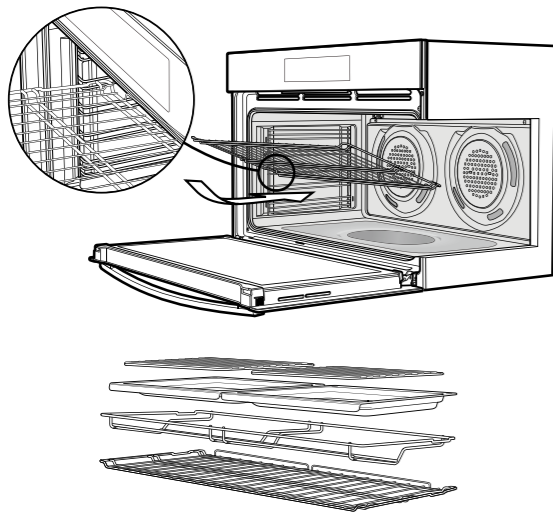

### Removing the side racks or shelf supports

- Grasp the shelf support at the front.
- Pull it firmly inwards

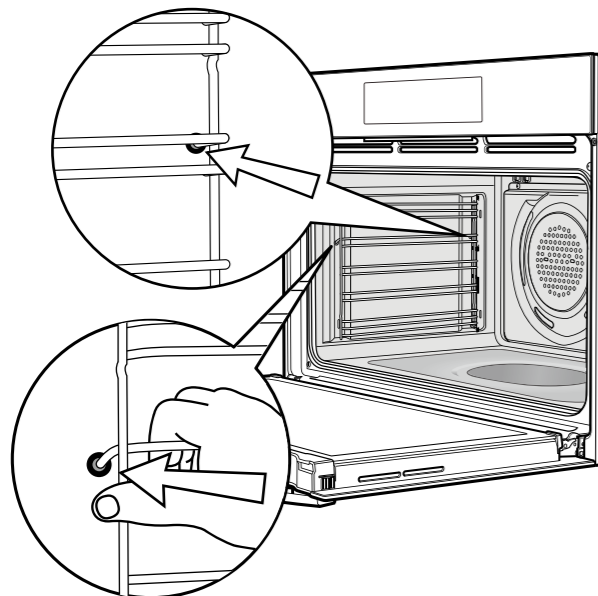

### Cleaning your oven door

The oven door has been designed to allow the two inner door glasses to be removed for cleaning without removing the door from the product.

Removing the inner door glass for cleaning:

- Open the door fully to gain access to the hinges.
- Push down the hinge locking tab as shown in the diagram on both sides of door.

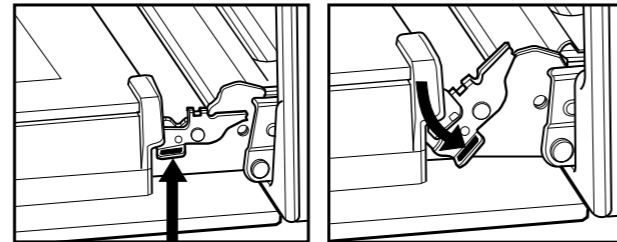

Locking tab up - normal position    Locking tab down - for cleaning

- Gently close the door until it stops in partially open position on the locking tab (the door will not fully close with the locking tab in the down position).
- In this position the top door trim can be removed by pushing each side on the serrated surface to release the clips and lift the trim away from the door.
- To remove the inner glass, tilt top of glass towards the oven and lift out.
- The middle glass is removed in the same way.
- The inner side of outer glass can be cleaned in-situ when inner and middle glass is removed.
- Clean glass using detergent and warm water, wipe clean and dry thoroughly.

Re-assembling the door glass panels:

- Replace the middle glass back to the door. The middle glass is a clear pane and orientation of the glass is not important.
- Replace the inner glass back to the door, ensuring the side with black ceramic paint faces away from the oven cavity when door is closed.
- Fully open the door and return the locking tabs to their normal position and close the door.

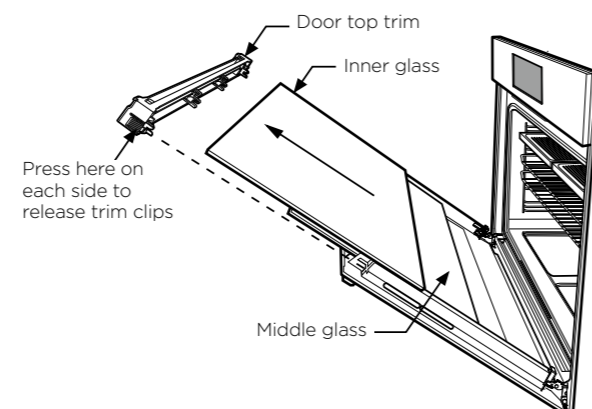

### Cleaning your oven door

#### WARNING

- DO NOT use the oven without the inner and middle door glass fitted.
- NEVER spray any caustic cleaners on any surface of the door or damage to the surface coatings will result.
- DO NOT use metal utensils, scrapers, scourers, or abrasive cleaners to clean the glass or any of the door trims. These will damage or scratch the surface coatings and degrade the finish and appearance.
- DO NOT place glass in dishwasher.
- Use only warm water and liquid detergent with a soft cloth to clean the glass or trims.
- Before refitting the glass panes to the door ensure they are dried with a soft cloth.
- The glass edges have been specially ground to remove any sharp edges. However it is glass, and should be handled carefully to avoid injury to your person and damage to the glass.

#### WARNING

Make sure the appliance power is switched off at the isolating switch before you remove or replace parts, to avoid the possibility of electric shock.

### Changing the light globes

- There are 2 light globes located in the top of the oven cavity towards the front. The light globe glass is accessible between the passes of the upper element.
- To remove, turn oven light glass anti-clockwise.
- A special high temperature resistant globe should be used. This can be purchased from the customer care centre.

### Storage compartment (selected models)

The storage compartment is accessible through the pivoting door.

Unused oven racks and grill dishes can be stored here.

#### WARNING

DO NOT store flammable or combustible items in the storage compartments. This is not a compartment for warming food.

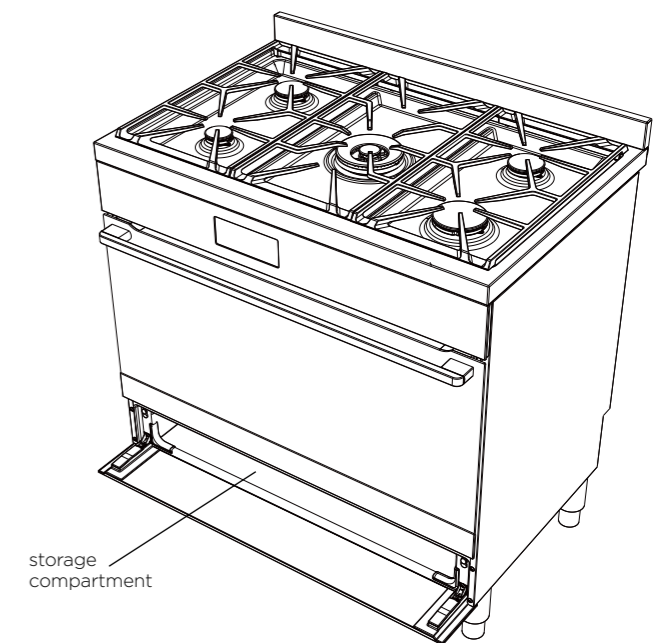

## TROUBLESHOOTING

### Faults

If there is a problem with the oven and/or grill, please:

- Check the points listed below before calling for service. It may be possible to avoid a call by fixing the problem yourself – and so continue cooking.

*NOTE: We may charge for service even in the guarantee period if your problem is due to the causes listed below.*

PROBLEM	POSSIBLE CAUSE	WHAT TO DO
Oven or grill not working	Power not turned on	Switch on electricity
	Household fuse blown	Check fuses
	Controls incorrectly set	Reset controls
	Circuit breaker tripped	Check circuit breaker
	Clock not set	Set time of day on timer
	Demo Mode 'ON'	Deactivate DEMO Mode. Refer to 'Using your oven'
Oven not heating enough	Child Lock 'ON'	Deactivate Child Lock. Refer to 'Using your oven'
	Foil or trays on bottom of oven Oven not pre-heated	Remove foil or trays Pre-heat oven for 30 mins
Light & fans on continuously	Timer not in manual mode	Set timer to manual mode
Oven not working	Timer not in manual mode	Set timer to manual mode
	Household fuse blown	Check fuses
Oven light not working	Household fuse blown	Check fuses
	Circuit breaker tripped	Check circuit breaker
	Lamp blown or loose in socket	Replace or tighten lamp
Cooker smoking when first used	Protective oils being removed	Turn grill on high for 30 mins and then the oven on 220°C for 1 hour
Too much condensation building up when baking	Too much water used when cooking	Reduce amount of water Leave oven door open after cooking
	Smells when first using oven	Protective oils being removed
Timer flashing	Power failure or interruption	Reset time of day
Burner will not light even though the sparker is working	Knob not held down long enough in 'High' position for flame safeguard (where fitted) to engage	Repeat lighting procedure and hold knob down for 5 seconds in 'High' position
	Gas supply valve turned off	Turn on gas supply to appliance
	Wrong knob turned off	Ensure the knob you are turning corresponds to the burner you wish to light
	Port blockage in ignition area	Ensure the ports in the ignition area are clean and dry
No spark is obtained when control knob is activated	Ignition spark plugs wet or dirty	Dry or clean ignition spark plugs
	Electricity supply is disconnected or switched off	Switch on electricity or check fuses
Flames uneven or tending to lift	Ignition spark plugs wet or dirty	Dry or clean ignition spark plugs
	Flame ports blocked or wet	Clean or dry flame ports
	Burner incorrectly fitted	Ensure this component is fitted correctly

*NOTE: Only authorised personnel should carry out servicing. If the household fuse continues to blow, call the Customer Care Centre. In the event of a power failure the gas burners may be lit with a hand held igniter and used. Take care to avoid letting unburnt gas flow for more than 5 seconds when attempting to light the burner.*

PROBLEM	POSSIBLE CAUSE	WHAT TO DO
Flames not staying on when knob released	Knob not held down long enough in 'High' position for flame safeguard (where fitted) to engage	Repeat lighting procedure and hold knob down for 5 seconds in 'High' position
	Knob not set between 'High' and 'Low'	Knob MUST be set between these positions
	Dirt or spillage on flame safeguard sensor (where fitted)	Clean flameguard sensor tip
Low heat, slow cooking	Incorrect cooking pot or pan being used	Refer to cooktop section for correct selection
Benchtop or knobs overheating	Incorrect cooking pot or pan being used	Refer to cooktop section for correct selection
	Pot or pan not located on burner properly	Ensure pot or pan is centrally located on burner
Stains appear to be under ceramic glass	These marks are on the surface of the ceramic glass	Clean marks off with a razor blade scraper and ceramic glass cleaner.
Shelf or telescopic runner slides out when door is opened	Oven cavity is not level with the ground.	Perform a check using a level to verify cause (refer to installation section). If not level refer to installer
Oven seal is loose	The oven seal is only attached at each corner. It may seem like a loose fit but when the oven door is closed it will function correctly	No action necessary
There is warm air coming from the top of the oven door	The oven vent is located under the control panel. When the oven is on, the air passes through this vent. This venting is necessary for proper air circulation in the oven and good baking results. Do not block vent.	No action necessary

### Further information

When you need information, service or replacement parts or have a warranty enquiry, please contact the Customer Care Centre:

- Australia - 13 13 49, 8.00am - 5.00pm EST Monday to Friday
- New Zealand - 0800 10 66 10, 8.00am - 5.00pm EST Monday to Friday

Please have the following information ready: Model, Model Number & Serial Number. This is shown on the data plate which is visible when the oven door is open.

**NOTE**

**This document sets out the terms and conditions of the product warranties for Westinghouse Appliances. It is an important document. Please keep it with your proof of purchase documents in a safe place for future reference should there be a manufacturing defect in your Appliance. This warranty is in addition to other rights you may have under the Australian Consumer Law.**

- 1. In this warranty:**
  - (a) 'ACL' or 'Australian Consumer Law' means Schedule 2 to the Competition and Consumer Act 2010;
  - (b) 'Appliance' means any Electrolux product purchased by you and accompanied by this document;
  - (c) 'ASC' means Electrolux's authorised serviced centres;
  - (d) 'Westinghouse' is the brand controlled by Electrolux Home Products Pty Ltd of 163 O'Riordan Street, Mascot NSW 2020, ABN 51 004 762 341 in respect of Appliances purchased in Australia and Electrolux (NZ) Limited (collectively "Electrolux") of 3-5 Niall Burgess Road, Mount Wellington, in respect of Appliances purchased in New Zealand;
  - (e) 'Warranty Period' means the period specified in clause 3 of this warranty;
  - (f) 'you' means the purchaser of the Appliance not having purchased the Appliance for re-sale, and 'your' has a corresponding meaning.
- 2. Application:** This warranty only applies to new Appliances, purchased and used in Australia or New Zealand and is in addition to (and does not exclude, restrict, or modify in any way) other rights and remedies under a law to which the Appliances or services relate, including any non-excludable statutory guarantees in Australia and New Zealand.
- 3. Warranty Period:** Subject to these terms and conditions, this warranty continues in Australia for a period of 24 months and in New Zealand for a period of 24 months, following the date of original purchase of the Appliance.
- 4. Repair or replace warranty:** During the Warranty Period, Electrolux or its ASC will, at no extra charge if your Appliance is readily accessible for service, without special equipment and subject to these terms and conditions, repair or replace any parts which it considers to be defective. Electrolux may, in its absolute discretion, choose whether the remedy offered for a valid warranty claim is repair or replacement. Electrolux or its ASC may use refurbished parts to repair your Appliance. You agree that any replaced Appliances or parts become the property of Electrolux.
- 5. Travel and transportation costs:** Subject to clause 7, Electrolux will bear the reasonable cost of transportation, travel and delivery of the Appliance to and from Electrolux or its ASC. Travel and transportation will be arranged by Electrolux as part of any valid warranty claim.
- 6. Proof of purchase** is required before you can make a claim under this warranty.
- 7. Exclusions:** You may not make a claim under this warranty unless the defect claimed is due to faulty or defective parts or workmanship. This warranty does not cover:
  - (a) light globes, batteries, filters or similar perishable parts;
  - (b) parts and Appliances not supplied by Electrolux;
  - (c) cosmetic damage which does not affect the operation of the Appliance;

- (d) damage to the Appliance caused by:
  - (i) negligence or accident;
  - (ii) misuse or abuse, including failure to properly maintain or service;
  - (iii) improper, negligent or faulty servicing or repair works done by anyone other than an Electrolux authorised repairer or ASC;
  - (iv) normal wear and tear;
  - (v) power surges, electrical storm damage or incorrect power supply;
  - (vi) incomplete or improper installation;
  - (vii) incorrect, improper or inappropriate operation;
  - (viii) insect or vermin infestation;
  - (ix) failure to comply with any additional instructions supplied with the Appliance;

In addition, Electrolux is not liable under this warranty if:

- (a) the Appliance has been, or Electrolux reasonably believes that the Appliance has been, used for purposes other than those for which the Appliance was intended, including where the Appliance has been used for any non-domestic purpose;
- (b) the Appliance is modified without authority from Electrolux in writing;
- (c) the Appliance's serial number or warranty seal has been removed or defaced

- 8. How to claim under this warranty:** To enquire about claiming under this warranty, please follow these steps:
  - (a) carefully check the operating instructions, user manual and the terms of this warranty;
  - (b) have the model and serial number of the Appliance available;
  - (c) have the proof of purchase (e.g. an invoice) available;
  - (d) telephone the numbers shown below.

**9. Australia:** For Appliances and services provided by Electrolux in Australia: Electrolux goods come with guarantees that cannot be excluded under the Australian Consumer Law. You are entitled to a replacement or refund for a major failure and for compensation for any other reasonably foreseeable loss or damage. You are also entitled to have the Appliance repaired or replaced if the Appliance fails to be of acceptable quality and the failure does not amount to a major failure. 'Acceptable quality' and 'major failure' have the same meaning as referred to in the ACL.

**10. New Zealand:** For Appliances and services provided by Electrolux in New Zealand, the Appliances come with a guarantee by Electrolux pursuant to the provisions of the Consumer Guarantees Act, the Sale of Goods Act and the Fair Trading Act. Where the Appliance was purchased in New Zealand for commercial purposes the Consumer Guarantee Act does not apply.

**11. Confidentiality:** You accept that if you make a warranty claim, Electrolux and its agents including ASC may exchange information in relation to you to enable Electrolux to meet its obligations under this warranty.

**Important Notice**

Before calling for service, please ensure that the steps listed in clause 8 above have been followed.

<b>AUSTRALIA</b>	<b>FOR SERVICE</b> or to find the address of your nearest authorised service centre in Australia <b>PLEASE CALL 13 13 49</b> <small>For the cost of a local call</small>	<b>FOR SPARE PARTS</b> or to find the address of your nearest spare parts centre in Australia <b>PLEASE CALL 13 13 50</b> <small>For the cost of a local call</small>
<b>NEW ZEALAND</b>	<b>FOR SERVICE</b> or to find the address of your nearest authorised service centre in New Zealand <b>PLEASE CALL 0800 10 66 10</b>	<b>FOR SPARE PARTS</b> or to find the address of your nearest spare parts centre in New Zealand <b>PLEASE CALL 0800 10 66 20</b>

**For more information on all Westinghouse appliances, or for dimension and installation information, call into your retailer, phone or email our customer care team or visit our website:**

**AUSTRALIA**

phone: 13 13 49

email: [customercare@electrolux.com.au](mailto:customercare@electrolux.com.au)

web: [westinghouse.com.au](http://westinghouse.com.au)

**NEW ZEALAND**

phone: 0800 10 66 10

email: [customercare@electrolux.co.nz](mailto:customercare@electrolux.co.nz)

web: [westinghouse.co.nz](http://westinghouse.co.nz)

 and WESTINGHOUSE are trademarks of Westinghouse Electric Corporation.  
Used under license by Electrolux Home Products Pty Ltd. All Rights Reserved.

© 2023 Electrolux Home Products Pty Ltd  
ABN 51 004 762 341  
W\_MAN\_WFE9515SD\_A26335901\_A4\_June 25