

**Enjoy peace of mind.
Register your appliance today.**

Stay updated on better living services, safety notices and shop for accessories.

1. Open the camera app on your smartphone and point at the QR code to scan

Product Registration QR code is located on the front of your appliance or inside the door rim*.

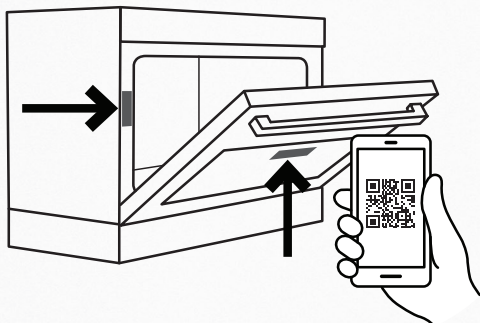

2. Tap the notification or link to open the registration form

3. Complete your details and enjoy peace of mind

*Exact location of QR code may vary depending on oven model



540MM UPRIGHT COOKERS

WLE522, WLE524, WLE530, WLE532, WLE543,
WLG510, WLG512

CONGRATULATIONS

Congratulations and thank you for choosing our Westinghouse upright cooker. We are sure you will find your new appliance a pleasure to use and a great asset to your cooking. Before you use the appliance, we recommend that you read through the whole user manual which provides a description of the product and its functions. For future reference, please store this booklet in a safe place.

To avoid the risks that are always present when you use a gas appliance, it is important that the appliance is installed correctly and that you read the safety instructions carefully to avoid misuse and hazards.

This appliance complies with the requirements of Australia/ New Zealand standards AS/NZS 60335.2.6 and AS/NZS 5263.1.1

CONDITIONS OF USE

This appliance is intended to be used in household and similar applications such as:

- Staff kitchen areas in shops, offices and other working environments.
- Farm houses.
- By clients in hotels, motels and other residential type environments.
- Bed and breakfast type environments.

Record model and serial number here:

Model:

Serial number:

The symbols you will see in this booklet have these meanings:



WARNING

This symbol indicates information concerning your personal safety.



CAUTION

This symbol indicates information on how to avoid damaging the appliance.



TIPS AND INFORMATION

This symbol indicates tips and information about use of the appliance.



ENVIRONMENTAL TIPS

This symbol indicates tips and information about economical and ecological use of the appliance.

CONTENTS

Important safety instructions.....	3
Installation	5
Operating for the first time.....	18
Installing oven accessories	19
Using the gas cooker	20
Using the electric cooker	23
3 button programmable clock.....	26
General hints and tips.....	27
Getting to know your oven	28
Cleaning the cooker.....	31
Oven guide.....	35
Trouble shooting.....	36
Notes.....	37
Warranty.....	39



TIPS AND INFORMATION

Important – CHECK FOR ANY DAMAGE OR MARKS

If you find the appliance is damaged or marked, you must report it within 7 days if you wish to claim for damage/ marks under the manufacturer's warranty. This does not affect your statutory rights.



ENVIRONMENTAL TIPS

Information on disposal for users

- Most of the packing materials are recyclable. Please dispose of those materials through your local recycling depot or by placing them in appropriate collection containers.
- If you wish to discard this product, please contact your local authorities and ask for the correct method of disposal.

Before making a service call

1. Please read the user manual carefully.
2. Cooking variations are natural and to be expected. You should experiment with times, temperatures and recipes to obtain the best results to your own taste.
3. New appliances can have an odour during the first operation.
 - It is recommended to 'run in' the oven before you cook. Run the oven at 180°C for 30 minutes and ensure that the room is well ventilated.
 - For products with separate grill compartment, run the grill on full for 15 minutes with the grill door open.
4. If you have purchased a model with a 3 button programmable clock, you will need to set the clock in order to begin using your oven.

IMPORTANT SAFETY INSTRUCTIONS

IMPORTANT INFORMATION THAT MAY IMPACT YOUR MANUFACTURER'S WARRANTY

Adherence to the directions for use in this manual is extremely important for health and safety. Failure to strictly adhere to the requirements in this manual may result in personal injury, property damage and affect your ability to make a claim under the Westinghouse manufacturer's warranty provided with your product. Products must be used, installed and operated in accordance with this manual.

You may not be able to claim on the Westinghouse manufacturer's warranty in the event that your product fault is due to failure to adhere this manual.



WARNING

To avoid an electric shock or fire

This appliance is NOT intended for use by persons (including children) with reduced physical, sensory or mental capability, or lack of experience and knowledge, unless they have been given supervision or instruction concerning use of the appliance by a person responsible for their safety.

WARNING - Accessible parts may become hot during use. To avoid burns, young children should be kept away.

Young children should be supervised to ensure they DO NOT play with this appliance.

DO NOT operate the hotplates with external timers or a separate remote control system.

During use this appliance becomes hot. Care should be taken to avoid touching hot external, internal surfaces and hot elements when in use. Use oven gloves.

This appliance must NOT be used as a space heater.

DO NOT install an aftermarket lid or cover over this appliance.

DO NOT spray aerosols in the vicinity of this appliance while it is in operation.

DO NOT use or store flammable materials in or near appliance.

Ensure all specified vents, openings and airspaces are NOT blocked.

Install cooker, shelving and fittings in accordance with the Guide and Installation Instructions, to avoid accidents.

DO NOT operate the gas appliance if the smell of gas persists.

DO NOT MODIFY THIS APPLIANCE.

The cooking process has to be supervised. A short term cooking process has to be supervised continuously.



WARNING

Grill warnings

DO NOT leave grill on unattended.

Fat left on a grill dish is a fire hazard! Keep grill clean and turn off grill immediately after use.

If gas burner does not light in 8 seconds, allow one minute for gas to clear before trying again.

Placing thick portions of food under grill can be a fire hazard.

DO NOT cover the grill dish insert with foil.



CAUTION

Separate grill model: Grill with door open.

Grill in oven model: Grill with door closed.

DO NOT line oven with foil or place anything on the bottom of the oven while baking, as trapped heat will crack or craze the floor of the oven cavity liner.

DO NOT use polyunsaturated oils (vegetable oils) as this type of oil can cause black spots or deposits inside the oven. This residue is very difficult to remove.

DO NOT allow pots to boil dry, as damage to the hotplate (and pan) may result.

DO NOT operate without a pot, fry pan etc on the hotplates.

DO NOT allow cookware to overhang the hotplate onto adjacent bench tops, this will cause scorching to the bench top surface.



WARNING

Oven warnings

DO NOT use the oven door as a shelf.

DO NOT push down on an open oven door.

If the gas oven does not light in 8 seconds, allow 1 minute for gas to clear before trying again.



WARNING

Hotplate and burner warnings

DO NOT use large utensils that may become unstable.

Gas models: Ensure burner caps and crowns are in their correct position.

GENERAL APPLIANCE DESCRIPTION

Do not store items on the cooking surface, to avoid a fire.

Unattended cooking on a hob with fat or oil can be dangerous and may result in a fire.

Electric and Gas Separate Grill Ovens depicted

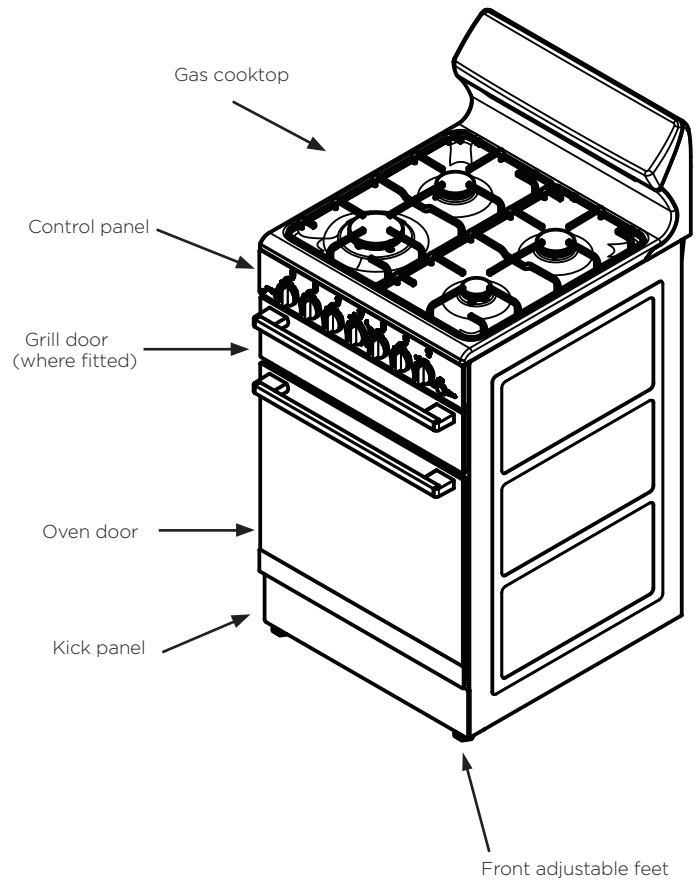
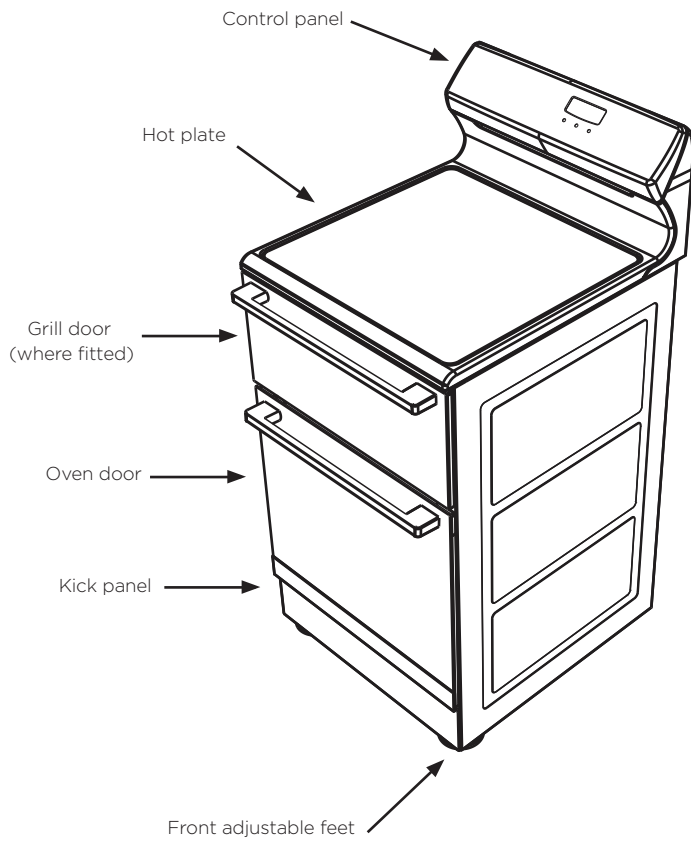

INSTALLATION

Installation and service warning

WARNING

- Only an authorised person must install and service this appliance (Certificate of Compliance to be retained).
- In order to avoid a hazard, the installation instructions MUST be followed.
- In order to avoid the appliance tipping, the anti-tilt plate MUST be installed.
- Appliances requiring connection to 230 - 240V MUST be earthed.
- An authorised person should inspect this appliance every 5 years.
- This appliance must NOT be installed on a base, box or in a closed cupboard.
- If the electrical supply cord is damaged, a qualified person MUST replace the cord to avoid a hazard or void your warranty.

WARNING

Surrounding kitchen cabinets MUST WITHSTAND 85°C.

Location

This appliance must not be placed on a base. This appliance must not be installed behind a decorative door.

The appliance has been designed to fit a 550mm gap in kitchen cabinetry or have free space on either side. Ensure the top of the hotplate is at least 10mm higher than the level of the benchtop.

Electric hob models must not be installed in a corner; they must be installed at least 100mm from the side wall.

Gas hob models must be installed with a minimum clearance of 100mm to side walls made of unprotected combustible material. For gas models, refer to specific requirements in AS/NZS 5601 for all relevant clearance.

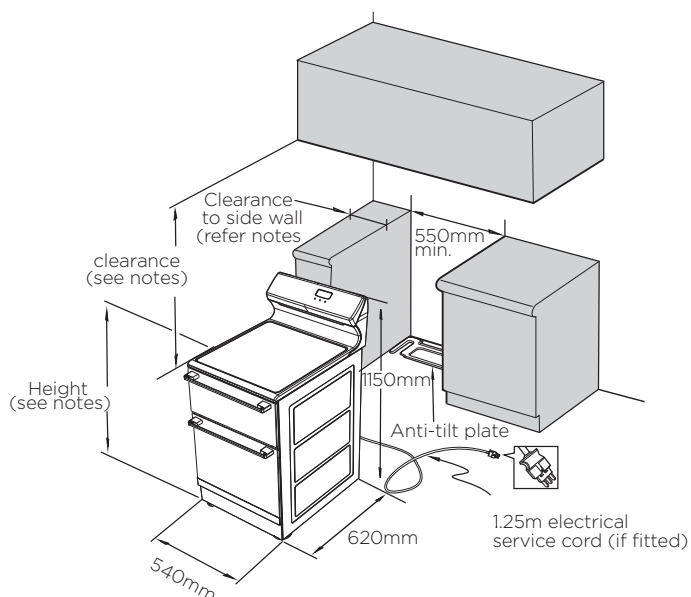

The following table outlines the distance between the floor supporting the product and supporting surface of the cooking vessel:

Surface type (supporting vessel)	Height(mm)
Electrical-Coil	910
Electrical-Ceramic glass	903
Gas-Enamel trivets	927

Overhead clearance

WARNING

Where the range hood or exhaust fan manufacturer's relevant instructions specify a greater clearance, then this greater clearance shall apply.

Clearance to any overhead surface shall be not less than 450mm.

For Electric Models

The overhead clearance between the supporting surface of this appliance and a range hood or exhaust fan shall be not less than 600mm.

For Gas Models

For existing installations where only the gas appliance is being replaced:

The overhead clearance from the highest part of the highest burner or the hob of this gas appliance to the range hood shall be not less than 600mm and not less than 750mm for an exhaust fan.

Any other downward facing combustible surface less than 600mm above from the highest part of the highest burner of this gas appliance shall be protected for the full width and depth of the hob in accordance with AS/NZS 5601.

For all other installations:

The overhead clearance between the supporting surface for the cooking vessels (top of the trivets) of this gas cooking appliance and a range hood or exhaust fan (overhead clearance) shall be not less than 650mm for a range hood, and not less than 750mm for an exhaust fan.

A range hood or exhaust fan shall be installed in accordance with the range hood or exhaust fan manufacturer's relevant instructions.

Any other downward facing combustible surface less than 650mm above the supporting surface for the cooking vessels shall be protected for the full width and depth of the hob in accordance with AS/NZS 5601.

Note 1: Removable accessories such as a wok trivet that sits upon a hob trivet are not taken into account in determination of the supporting surface for the cooking vessels.

Note 2: Minor elevations in trivets such as a wok trivet formed into a trivet are not taken into account in determination of the supporting surface for the cooking vessels.

Note 3: The height of the top of the pan supports (top of the trivets) with respect to the bench top (built in) or supporting surface (elevated) or the floor (freestanding) are detailed separately in these instructions.

INSTALLATION

WARNING

In order to avoid accidental tipping of the appliance (for example, by a child climbing onto the open oven door), the anti-tilt plate and stabilising bolt MUST be installed.

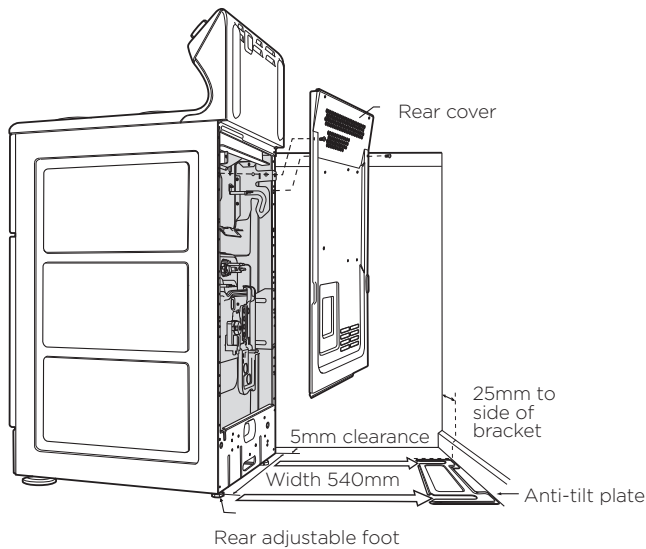

Position anti-tilt plate to the rear wall and 25mm from side of cupboard. Securely fix anti-tilt plate to the floor with fasteners. Adjust levelling feet on cooker as required.

Stabilising bolt

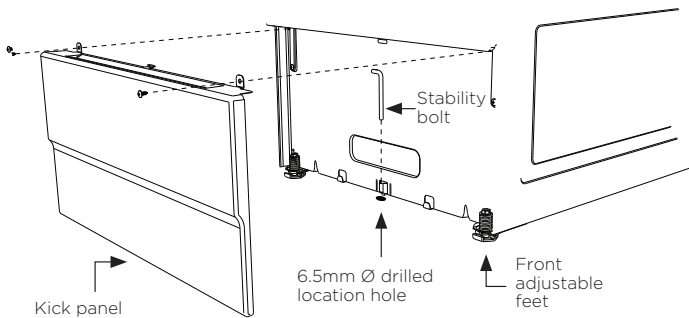

1. Remove oven door - to be done by qualified personnel only. (Refer to procedure).
2. Remove screws from kick panel. To remove kick panel lift kick panel upwards to release the two location tabs from the holes in the bottom of the panel.
3. Position cooker into the anti-tilt plate and then mark the position for the stability bolt hole on the floor.
4. Pull cooker out and drill the bolt hole, using a 6.5mm masonry or wood drill bit. The bolt hole needs to be a minimum of 30mm deep when fixing the oven to concrete.
5. Reposition cooker back into place and fit the stability bolt through the slot and into the drilled hole.
6. If the cooker is placed on a base, measures must be taken to prevent the appliance slipping from the base.
7. Carefully remove any protective plastic film to prevent damage to the appliance.

WARNING

For your safety this cooker is designed to be moved out of position by qualified person only.

The unit must be pushed up against the wall on installation. On gas units check that the gas hose, if used, has not been kinked during installation.

Removing the oven door

1. With door fully open, rotate the two stirrups to its rest position.

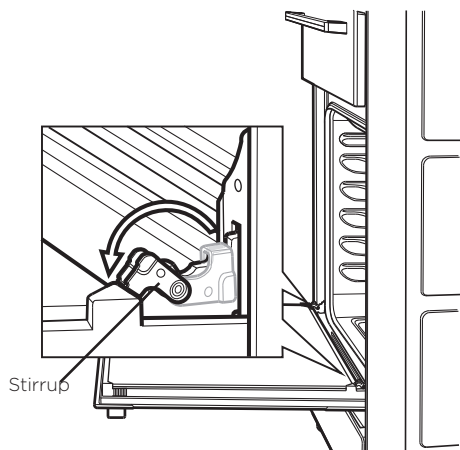

2. Close the door until it stops against the stirrups.

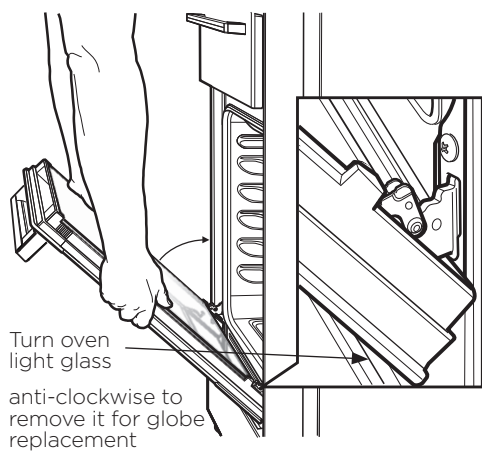

3. Close the door further.

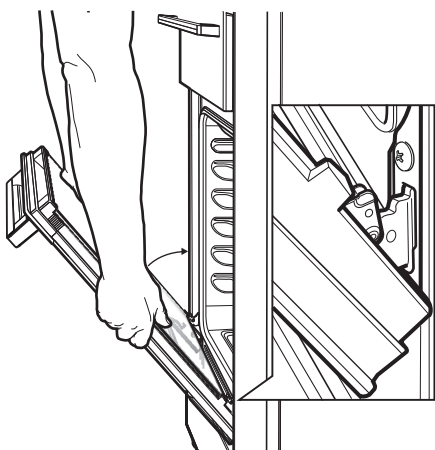

4. Lift the door slightly and evenly while continuing to slowly close the door.

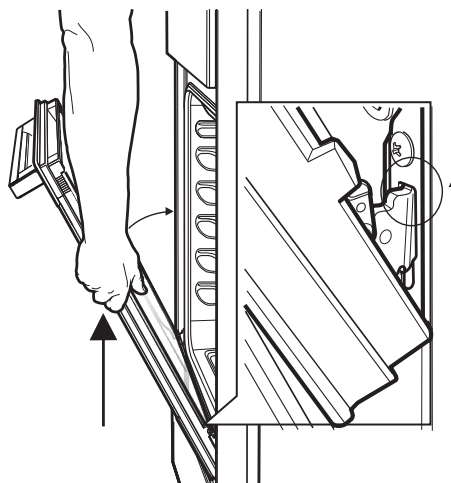

5. Remove the door by lowering gently and pull away from the frame of the oven. Care should be taken not to damage kick panel and other parts of the cooker.

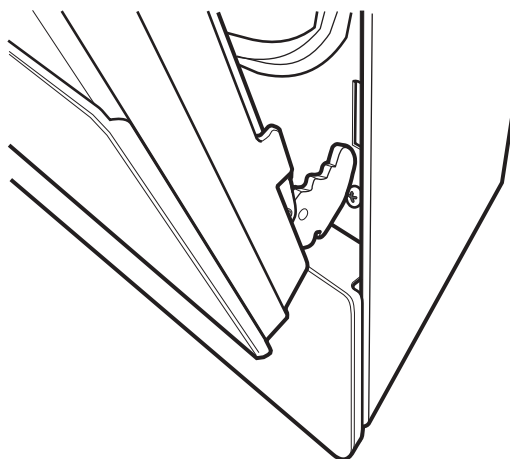

INSTALLATION

Replacing the oven door

1. Hold door with both hands.
2. Locate both hinges into the frame slots at the same time.

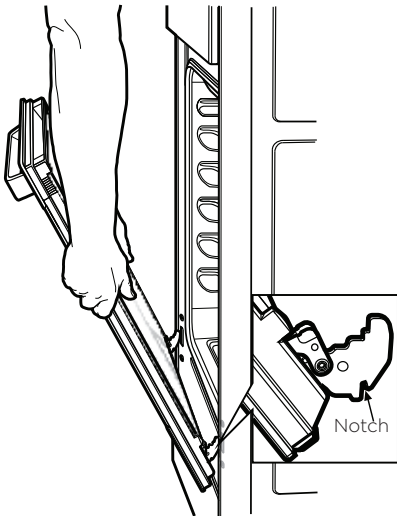

3. Ensure that the location notch drops into frame slot. Care should be taken not to damage other parts of the cooker.

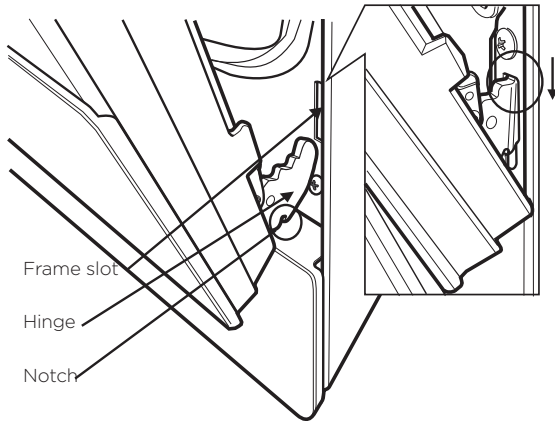

4. Open door fully and rotate stirrups away from you back to their original position.

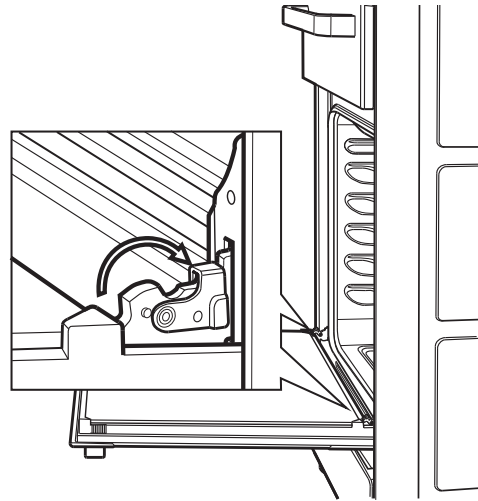

5. Close the door fully.
6. Carefully remove any protective plastic film to prevent damage to the appliance.

Service fuse/circuit breaker location – Models with power point only

This product is fitted with a power outlet at each end of the control panel. The outlets are protected by a replaceable 15 amp fuse or a 15 amp circuit breaker located at the rear.

WARNING

Before servicing the fuse, ensure that all power to the product is switched off.

To access fuse, unscrew fuse housing and remove from appliance (See diagram). For circuit breaker, push to reset.

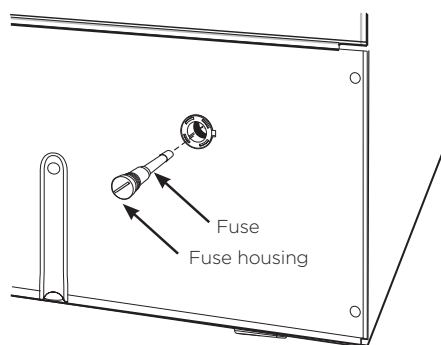

Electric wiring requirements

The cooker MUST be installed in compliance with:

- Wiring connections in AS/NZS 3000 wiring rules.
- Local regulations, municipal building codes and other statutory regulations.
- Data plate – Gives information about the rating and is located behind the bottom of the oven door.

For New Zealand only: The cooking range must be connected to the supply by a supply cord fitted with the appropriately rated plug that is compatible with the socket-outlet fitted to the final sub-circuit in the fixed wiring that is intended to supply this cooking range.

- A functional switch MUST be provided near the appliance in an accessible position (AS/NZS 3000).
- Wiring MUST be protected against mechanical failure (AS/NZS 3000).
- The cooker requires a means of all pole disconnection incorporated into the fixed wiring. This MUST have a disconnection gap of 3mm.
- The cooker MUST be properly earthed.
- Disconnection in the fixed wiring must occur in accordance with the AS/NZS 3000 Wiring Rules.
- If the supply cord is damaged, it must be replaced by the manufacturer, its service agent or similarly qualified persons in order to avoid a hazard.
- This range must be connected with cable of 75°C rating minimum.
- This product has passed the insulation resistance test after manufacture. If the resistance reading is low at installation, it is probably caused by moisture from the atmosphere being absorbed by the elements after the range has been produced. (AS/NZS 3000).

IMPORTANT

Before you cook in your new oven it is important that the protective oils used in the manufacture of the product be removed. Refer to 'Before Operating your Appliance for the First Time' in the Using The Oven section.

Hard wiring

1. Remove rear panel.
2. Fit wires through hole at bottom centre using the appropriate gland to protect insulation of wires from the hole edge. Note that the secondary insulation of the wires will probably need to be removed to fit through gland. If the conduit to appliance is required to bend due to rear wall an elbow may be required to achieve this.
3. Set the length of wiring from the gland to terminal block, ensuring length is Sufficient but not excessive.
4. Make connections to terminals and engage wires into plastic clip. Cable tie as per diagram and secure plastic clip with two long screws supplied.
5. Replace rear cover.

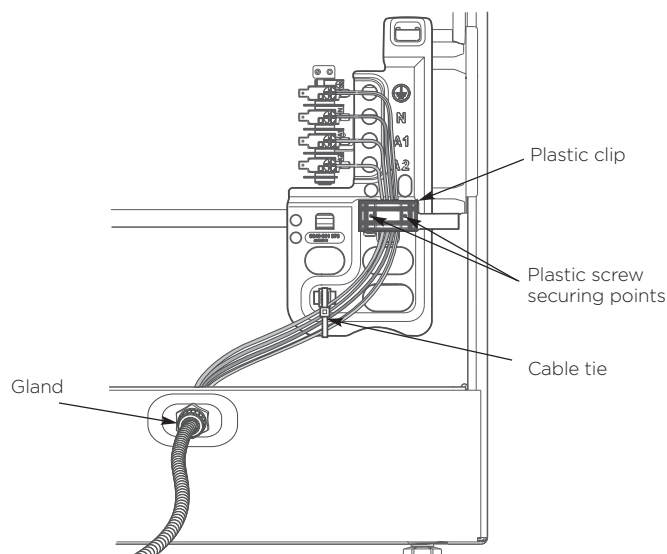

Rated power input

MODEL	TOTAL kW	A1 kW	A2 kW
WLE522	9.9	4.0	5.8
WLE524	10.0	4.2	5.8
WLE530	9.1	3.6	5.5
WLE532	9.6	4.0	5.5
WLE543	9.7	4.0	5.6

INSTALLATION

Gas requirements

This appliance must be installed by an authorised person, according to all codes and regulations of:

- AS/NZS 5601.
- Local gas fitting regulations, municipal building codes and other statutory regulations.

The burner crowns, burner caps and trivets can be fitted to the hob.

The gas regulator can be found in the internal pack.

The cooker is configured for natural gas. Refer to gas conversion instructions for conversion to other gas types.

Unpacking

When packaging is removed from product you will notice there are several items nested in the packaging base.

The following table shows the supply and operating pressures for various supplies.

GAS TYPE	NATURAL GAS	PROPANE
Supply pressure at inlet to appliance regulator	1.13 -5.00(kPa)	2.75 * -7.00(kPa)
Operating pressure at appliance test point	1.00 (kPa)	2.75 (kPa)

*If the supply pressure is 2.75 kPa the gas regulator must still be installed to provide the test point.

Checking pipe size

To work out a suitable pipe size for connection use the information in this table.

	NATURAL GAS		PROPANE	
Model	WLG510	WLG512	WLG510	WLG512
Hourly gas consumption for cooker	58.1MJ	60.2MJ	56.5MJ	58.3MJ

Also use information about the length of the run, number of elbows, tees and bends, the available service pressure and the supply requirements. AS/NZS 5601 will help you with this matter.

Gas regulator

- The appliance regulator MUST be orientated so that the pressure nipple is accessible.
- The arrow showing the direction of flow MUST be pointed correctly.
- The regulator has a ½" BSP internal thread at the inlet and outlet.

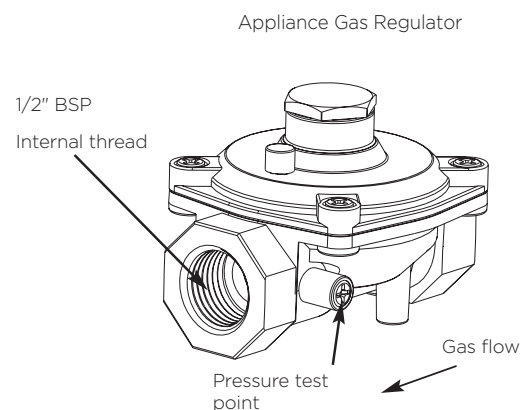

INSTALLATION

Wiring connection for gas cooker

To allow for disconnection of the appliance after installation, the plug must be accessible after installation.

If the supply cord is damaged, it must be replaced by the manufacturer, its service agent or similarly qualified persons in order to avoid a hazard.

Gas connection

Read these points before connecting to the gas supply:

- The cooker inlet connection point has a ½" BSP external thread. See diagram below.
- An Appliance Gas regulator is supplied and must be fitted.
- It is recommended to fit the regulator or test point fitting to the appliance connection point, then fit either hard piping or a high level flexible connection (AS/NZS 5601) which is then attached to the consumer hard piping.
- Ensure installation allows withdrawal of appliance.
- Installation of a means of isolation before the gas regulator is recommended.

Checking the gas supply

1. Check the manometer zero point is correct.
2. Connect the manometer to the cooker pressure test point. This is located on the gas regulator.
3. Turn on the gas supply and the electricity (if applicable) and try to ignite the gas.

NOTE: It will take additional time to light the gas for the first time, as air needs to be purged from the pipes.

4. Check the operating pressure for the particular gas type (see 'Gas Type' table).

Regulators are supplied pre-adjusted and configured by the component maker for use with Natural Gas. The appliance installer is not required to make an adjustment to obtain the correct outlet pressure setting. An arrow on the base of the regulator indicates the direction of the gas flow when the inlet and outlet of the regulator are orientated correctly.

5. Check for leaks from the connections with soapy water or leak detector.

Checking regulator function

With the appliance operating, check the outlet pressure:

1. When all the burners of the appliance are operating at maximum.
2. When the smallest burner of the appliance is operating at minimum.

Under both these conditions the outlet pressure should not vary from nominal operating pressure of 1.0kPa by more than $\pm 20\%$ (1.00 \pm 0.20 kPa for Natural Gas). (2.75 \pm 0.55 kPa for Propane)

If the regulator does not appear to be performing satisfactorily then check the following points:

1. If the outlet pressure is consistently too low then
 - the inlet pressure may be too low and adjustment of an upstream regulator may be needed, or
 - an upstream regulator or valve with insufficient flow capacity may be present in the gas supply line. It may be necessary to repeat the checks whilst measuring both the inlet and outlet pressure to determine if the inlet pressure is in the range 1.13-5kPa for Natural gas (2.75-7.00kPa Propane).
2. Check that the regulator has been fitted to the gas supply line in the correct orientation.
3. Replace the regulator if it fails to perform after the checks.

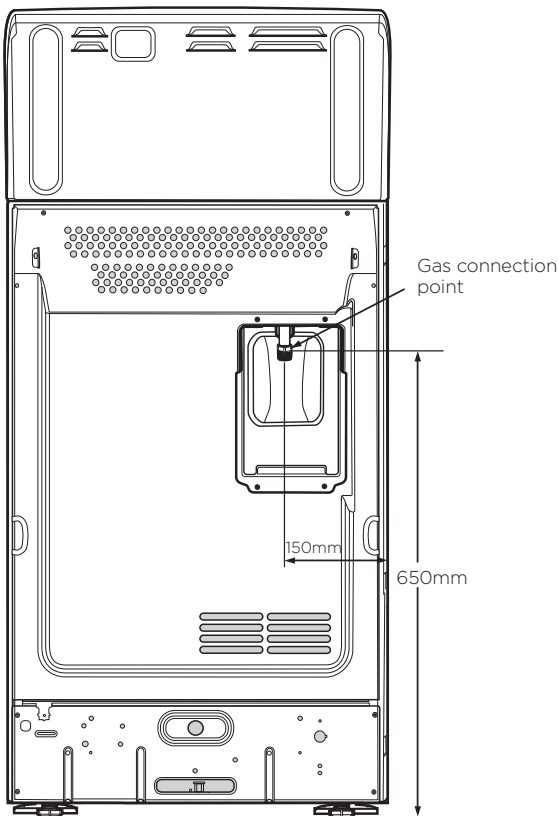

Testing the gas cooker



WARNING

You **MUST** test the cooker after installation, before you hand it over to the customer.

You **MUST** have a manometer and a connecting tube.

Testing Burner Performance

- Observe the flame appearance on each burner when set to max. If it is smaller or larger than expected, then the injector size needs checking (refer to table).
- When maximum flame appearance is correct, check the turn down setting on each burner. If incorrect, refer to gas conversion instructions for turn down adjustment.

GAS CONVERSION INSTRUCTIONS

Conversion to SNG or ULPG (NZ only)

A conversion kit and instructions can be obtained by contacting the Customer Care Centre.

Conversion to Propane Gas

For conversion to Propane gas type, all gas injectors need to be changed, all gas valves are adjusted, the gas regulator is converted. If the conversion kit is not with the appliance, please reach out to Customer care team at 131349 (if you are in Australia) or 0800436245 (if you are in New Zealand) or by email.

After converting the appliance, attach the LPG sticker to the cooker, near the gas supply inlet. Cover the Natural Gas label that is factory fitted.

Important: The conversion must be performed by a qualified service technician in accordance with the kit instructions and all local codes and requirements. Failure to follow instructions could result in serious injury or property damage.

Depending upon the model of the cooker not all gas injectors in the conversion kit will be used.

WARNING

Failure to convert the cooker in accordance with these instructions can result in serious personal injury and property damage.

Note: Always perform a gas leak test after converting the appliance.

Gas Hob Conversion

Tools required:

- 7mm hex socket screwdriver or 7mm nut runner.
- Small flat-blade screwdriver.

1. Remove trivets/pan supports, burner crown, and top caps from burner bases.
2. Using a 7mm socket, remove Natural Gas injectors.
3. Using the Injector table and hob layout diagram, select the correct gas injector for each burner and intended gas type.
4. Using a 7mm socket, screw in gas injectors. Set injectors in place firmly but not with excessive torque.
5. Reinstall trivets/pan supports, burner crown, and top caps ensuring that these components are sitting correctly on their respective lower parts.
6. If Gas Separate Grill is provided, please go to "Gas Separate Grill Conversion", otherwise proceed to the next step.
7. Remove all control knobs on the front of the cooker by gripping each knob behind its skirt and pulling away from the control panel.
8. Locate the recessed turndown adjustment screw in each gas valve, insert the screwdriver, and turn the adjustment screw clockwise until the screw stops.

Note: If a Gas Oven is present its control can be adjusted the same way. If access to adjustment screws is not clear, see "Gas Separate Grill Conversion" instructions on how to remove the control panel.

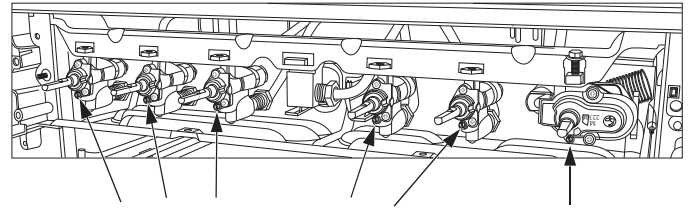

Adjustment screws at each gas valve for hob and gas grill where fitted

Adjustment screw for oven thermostat where fitted

Note: If the adjustment screw for the oven thermostat does not turn clockwise and is marked on the outer end with "73" then contact Electrolux Service. For Propane gas, the oven thermostat adjustment screw must be marked with "45" and set all the way in to the thermostat valve body.

9. Install control knobs (with separate skirts where used) by pushing them on fully.

Gas Separate Grill Conversion (Where used)

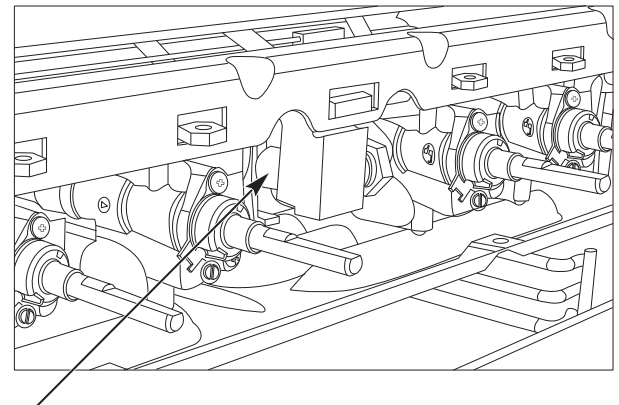

Injector on the injection block

Tools required:

- 7mm open-ended or ring spanner.
- #2 Phillips head screwdriver.

1. **Warning: Risk of electric shock.** Ensure the cooker is NOT plugged into a power point before proceeding.
2. Remove all control knobs on the front of the cooker by gripping each knob behind its skirt and pulling away from the control panel if not already done as part of the Gas Hob conversion.
3. Remove the control panel by removing the 2 screws behind the grill door below the Control Panel. Rest the control panel on the open grill door being careful not to stretch or damage the wiring.
4. **Warning: Risk of laceration.** The now exposed front edge and other edges of the grill compartment panel can have sharp edges. Wear appropriate gloves.
5. Remove the grill burner gas injector using the 7mm spanner from its holder in front of the aeration shutter. To loosen the injector, rotate the spanner in a clockwise direction as you are working from behind it.
6. Select the correct gas injector for the grill burner and the intended gas type and replace the grill burner gas injector. Set the injector in place firmly but not with excessive torque.

7. Locate the recessed turndown adjustment screw in each gas valve, insert the screwdriver, and turn the adjustment screw clockwise until the screw stops. Note: All gas valves for the Gas Hob, Gas Oven, and Gas Separate Grill need to be adjusted the same way.
8. Replace the control panel being careful to ensure any wires do not get trapped between the grill compartment panel and the control panel as per the reverse of step 3.
9. Install control knobs (with skirts where used) by pushing them on fully.

Gas Oven - Freestanding Cookers (Where used)

Tools required:

- 7mm open-ended or ring spanner or 7mm hex socket screwdriver or nut runner.
- #2 Phillips head screwdriver.

1. **Warning: Risk of electric shock.** Ensure the cooker is NOT plugged into a power point before proceeding.
2. Remove the plastic cover behind the gas connection point by unscrewing 2x Phillips screws).
3. **Warning: Risk of laceration.** The rear cover and internal components can have sharp edges. Wear appropriate gloves and long sleeve & leg clothes.
4. Remove the rear panel by unscrewing 2 (or 4 where used) Phillips screws.
5. Inside the lower back of the cooker, remove the lower internal baffle plate (where fitted).

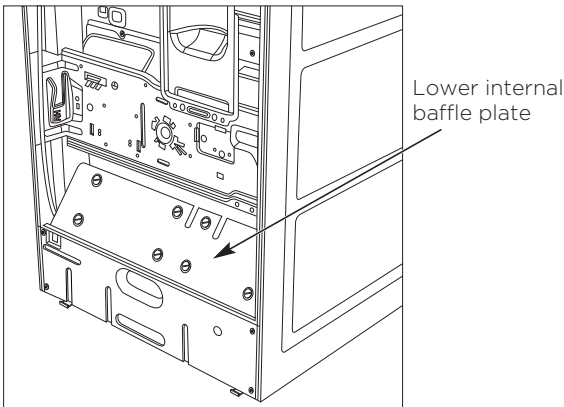

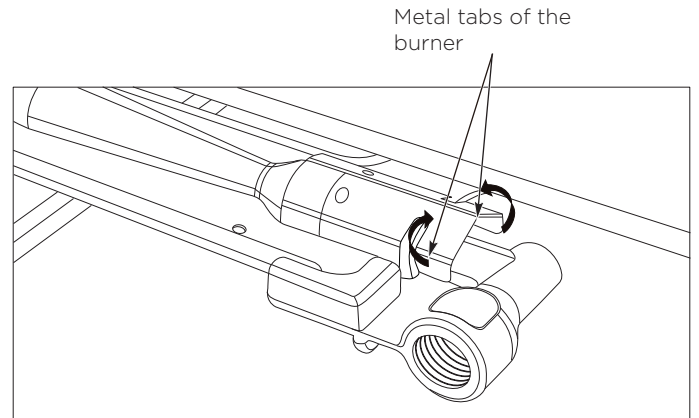

6. Remove the gas injector holder from the burner by bending up the 2 metal tabs at the end of the burner holding the gas injector, then slide the injector holder out of the burner body.



7. Remove the oven burner gas injector from its holder using the 7mm spanner or socket or nut runner.
8. Select the correct gas injector for the oven burner and the intended gas type and replace the oven burner gas injector. Set the injector in place firmly but not with excessive torque.
9. Slide the gas injector holder back into the burner and bend down the 2 metal tabs to ensure that the injector holder cannot slide out of the burner body.
10. Install the internal baffle (where used), rear cover, and plastic cover behind the gas connection as per the reverse of steps 1 to 4.

Note: Adjustment of the turndown of the Gas Oven valve (thermostat) should have been done as part of the Gas Hob Conversion.

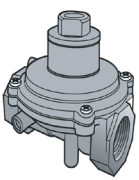
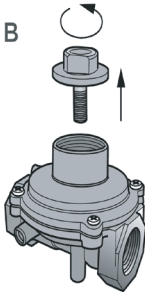
Gas Regulator Conversion

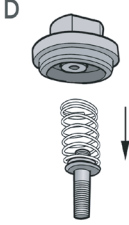
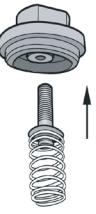
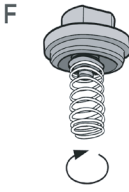
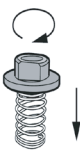
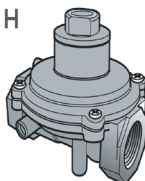
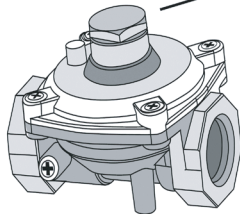
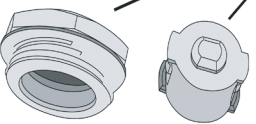
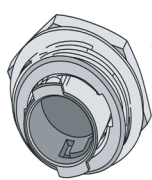
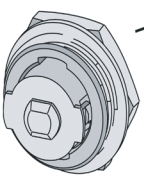
Chant Regulator	Dong Yang Regulator
<ol style="list-style-type: none"> 1. Unscrew the top hat nut from the regulator. The top hat nut and control pressure spring assembly will disengage as an assembly. See figures A&B. 2. Unscrew the threaded pin from top hat. See figures C&D. 3. Turn over threaded pin, so spring is free and screw pin back into the top hat until firm. See figures E&F. 4. Screw the top hat nut assembly back into the regulator ensuring that it is fully screwed down. See figures G&H. The regulator is now set for connection to LPG. 	<ol style="list-style-type: none"> 1. Unscrew the hex nut from the regulator. The hex nut, brass washer and nylon insert will disengage as an assembly. See Fig. 1. 2. Unclip the nylon insert from the nut assembly by rotating the insert ¼ turn, and pulling it free. See Fig. 2. 3. Turn over the insert, and clip back into position. See Fig. 3&4. 4. Screw the hex nut assembly back into the regulator ensuring that it is fully screwed down. The regulator is now set for connection to LPG.
<div style="display: flex; justify-content: space-around;"> <div style="text-align: center;">  <p>Top hat nut assembly, fully screwed down</p> </div> <div style="text-align: center;">  <p>Turn top hat nut anti-clockwise and remove</p> </div> </div> <div style="display: flex; justify-content: space-around; margin-top: 20px;"> <div style="text-align: center;">  <p>Configuration for Natural Gas</p> </div> <div style="text-align: center;">  </div> </div> <div style="display: flex; justify-content: space-around; margin-top: 20px;"> <div style="text-align: center;">  </div> <div style="text-align: center;">  <p>Configuration for LPG</p> </div> </div> <div style="display: flex; justify-content: space-around; margin-top: 20px;"> <div style="text-align: center;">  </div> <div style="text-align: center;">  </div> </div>	<div style="text-align: center; margin-bottom: 20px;">  <p>Hex nut assembly, fully screwed down</p> </div> <div style="text-align: center; margin-bottom: 20px;">  <p>Hex nut assembly, removed from regulator and insert disassembled</p> </div> <div style="text-align: center; margin-bottom: 20px;">  <p>Insert oriented for Natural Gas operation</p> </div> <div style="text-align: center;">  <p>Insert oriented for LPG operation</p> </div>

Commissioning Gas Type Conversion

Tools required:

- A manometer capable of reading from 0 to at least 3.0kPa.
1. Remove the Test Point (TP) from the appliance Gas Regulator and connect a manometer capable of reading from 0 to at least 3.0kPa.
 2. Turn on the gas supply to the appliance and test for leaks.

Gas Hob Commissioning

1. Turn on a Gas Hob burner to high and hold the gas valve control knob in. At the same time use the inbuilt igniter (240v powered models) or a gas match applied to that burner to provide an ignition source.
2. Once the burner is lit and after 5s release the valve knob and observe for the following:
 - a. Flames have traveled to all burner ports promptly.
 - b. Burner stays alight once gas valve knob is released.
 - c. Burner flames are almost entirely blue. Some light yellow within the flame may be present but there should be no yellow at the tip at the outer end of the flame.
 - d. The TP pressure as indicated by the manometer should be between 2.2kPa and 3.3kPa.(2.75kPa +/- 20%)
 - e. See "Fault Finding" if any of these requirements are not met.
3. Rapidly move the gas valve of the lit burner from high to low and back again a few times. The burner should stay alight. If the burner does not stay alight, adjust the turndown for that burner at the gas valve slightly counter- clockwise to increase the gas rate at minimum turndown. Refer to Gas Hob Conversion instructions for adjustment locations.
4. Shut off the burner and repeat for all other Gas Hob Burners.
5. Light all Gas Hob Burners and repeat step 2.

Table for injector sizes

The following table shows the injector sizes for each burner.

Burner	Injector Size (mm)		
	Natural gas (Nominal test point pressure: 1.00kPa)	Propane - For Australia only (Nominal test point pressure: 2.75kPa)	ULPG - For NZ only (Nominal test point pressure: 2.75kPa)
Intense heat wok burner	1.75	1.00	1.00
High heat burner	1.60	0.95	0.90
Medium heat burner	1.35	0.82	0.70
Low heat burner	1.00	0.62	0.55
Grill	1.50	0.82	0.82
Oven	1.60	0.95	0.82
Oven - bypass screw	0.73*	0.45	0.45

*0.45 from the factory adjusted for Natural gas. For conversion from Propane /ULPG to Natural gas, a "0.73" bypass screw is required.

Gas Separate Grill Commissioning (Where used)

1. Turn on the Gas Grill burner knob to high, press in, and hold the gas valve control knob in. At the same time use the inbuilt igniter to provide an ignition source.
2. Once the burner is lit and after 10s release the valve knob and observe the following:
 - a. Flames travel to all burner ports promptly.
 - b. Burner stays alight once gas valve knob is released.
 - c. Burner flames are almost entirely blue. Some light yellow within the flame may be present but there should be no yellow at the tip at the outer end of the flame.
 - d. The TP pressure as indicated by the manometer should be between 2.2kPa and 3.3kPa. (2.75kPa +/- 20%)
 - e. See "Fault Finding" if any of these requirements are not met.
3. Rapidly move the gas valve of the lit burner from high to low and back again a few times. The burner should stay alight. If the burner does not stay alight, adjust the turndown for that burner at the gas valve slightly counter- clockwise to increase the gas rate at minimum turndown. Refer to Gas Hob Conversion instructions for adjustment locations.

Gas Oven Commissioning (Where used)

1. Turn on the Gas Oven Thermostat to 120°C, press in, and hold the gas valve control knob in. At the same time use the inbuilt igniter to provide an ignition source.
2. Once the burner is lit and after 10s release the valve knob and observe the following:
 - a. Flames travel to all burner ports promptly.
Burner stays alight once gas thermostat knob is released.
 - c. Burner flames are almost entirely blue. Some light yellow within the flame may be present but there should be no yellow at the tip at the outer end of the flame.
 - d. The TP pressure as indicated by the manometer should be between 2.2kPa and 3.3kPa. (2.75kPa +/- 20%)
 - e. See "Fault Finding" if any of these requirements are not met.
3. Close the door and wait for the thermostat to operate and turn the burner down to maintain 120°C. The burner should stay alight. If the burner does not stay alight, adjust the turndown for the burner at the gas valve slightly counterclockwise. Refer to Gas Hob Conversion instructions on how to locate the adjustment screw.

FAULT FINDING

PROBLEM	POSSIBLE CAUSES	WHAT TO DO
Burner will not light	Gas not turned on	Check supply
	Air not purged from gas pipes	Purge gas pipe to appliances Keep gas valve open for a longer time while keeping ignition source present at that burner
	Ignition source not operating	Check appliance is plugged in and 240V power supply is available Check spark at burner (Gas Oven and Gas Separate Grill only with piezo ignition) Attempt to light burner with gas match to confirm presence of fuel gas
Burner flames are very big and/or very yellow	Incorrect Gas Injector size	Check injector against requirement in gas injector table for the required gas type
	Hob burner crown and/or cap not correctly set in place	Check that hob burner crown is seated in base and cap is seated on the burner crown
	Gas Oven injector holder not set in place or pipe bent at oven injector holder	Check oven injector holder is fully in the receptacle of the oven burner, adjust pipe to burner assembly to give blue flame
	Incorrect gas pressure	Check Gas Regulator outlet pressure at Test Point on Gas Regulator Check Gas Regulator inlet supply pressure Check that Gas Regulator conversion instructions have been followed correctly
Burner flames are small when gas valve on high	Incorrect Gas Injector size	Check injector against requirement in gas injector table for the required gas type
	Incorrect gas pressure	Check Gas Regulator outlet pressure at Test Point on Gas Regulator Check Gas Regulator inlet supply pressure Check that Gas Regulator conversion instructions have been followed correctly
Burner flames are uneven - Gas Hob Burners	Hob burner crown and/or cap not correctly set in place	Check that hob burner crown is seated in base and cap is seated on the burner crown
	Gas injector not screwed in correctly	Check that Gas Injector orifice is pointing straight up
Burner flames are uneven - Gas Separate Grill	Gas injector not screwed in correctly	Check that Gas Injector orifice is pointing straight down to the mixing tube of the grill burner
Burner flames are uneven - Gas Oven	Burner flames on the left is higher than the right side flames as looking at the oven	This is normal. No action required
	Gas injector not screwed in correctly or Gas injector holder not fitted correctly	Check that Gas Injector is fitted correctly, and injector assembly is inserted into burner
No ignition spark	Wires disconnected at the back of piezo ignitor (piezo ignition only)	Remove control panel and check wiring
	Wires disconnected at the back of switch (240V)	Turn off and disconnect from 240V outlet, then remove control panel to check no wires have become disconnected
	No 240V power	Check whether power supply is available and turn on

OPERATING FOR THE FIRST TIME

Choosing utensils for electric hotplates

Refer to the diagram below.

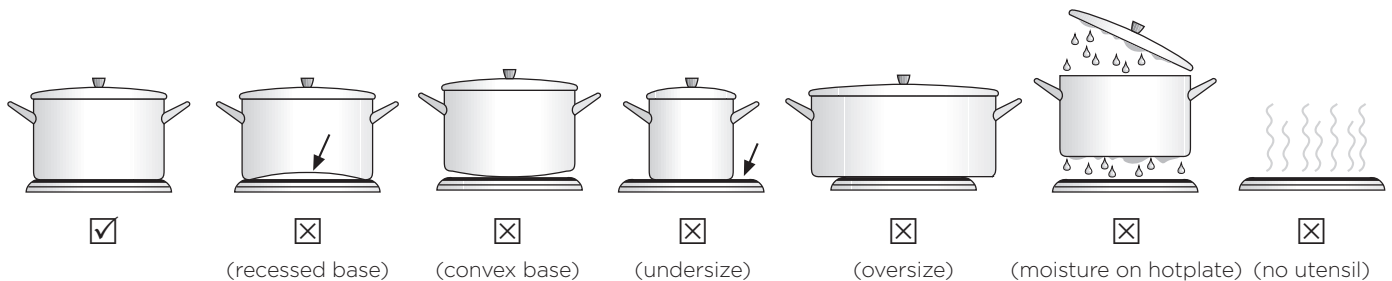

Choosing utensils for gas hotplates

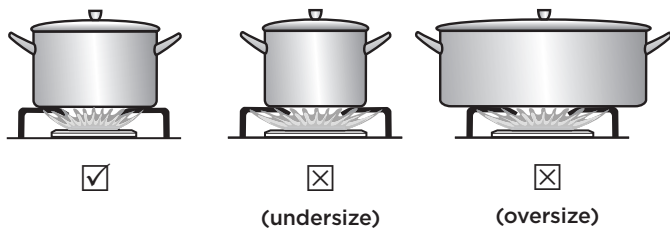

Do not use utensils which are too large or too small.

WARNING

- This cooker must have been installed by a competent person who will issue to the customer a certificate of compliance for any gas and or electrical (fixed wiring) work.
- In order to avoid a hazard, all installation instruction must have been followed.
- In order to avoid tipping, anti tilt plate and securing bolt into the floor must have been fitted. When installation is complete, the cooker must not be able to slide forward or tip forward.
- If the electrical supply cord is damaged, a qualified person MUST replace the cord to avoid hazard or void your warranty.
- If there is a smell of unburned gas, do not use the cooker, turn off gas supply (at the gas meter if necessary) and contact Electrolux customer service.

Before operating first time

1. Read all the Warning and Safety information.
2. Remove all internal boxes and bags from oven.
3. Clean out the oven interior with detergent and warm water and polish with a soft cloth. DO NOT close oven door until the oven is completely dry.

Setting the time

4. If you have purchased a model fitted with a 3 button programmable timer, you must set the time of day before you can operate your appliance.
 - After the appliance has been electrically connected '12:00' or '00:00' will be displayed and the 'clock indicator' will flash.
 - To set the time of day, press the - or + buttons. 5 seconds after the last change, the 'clock' indicator will disappear, confirming the time has been set.

NOTE: The clock has a 24-hour display.



5. New appliances can have an odour during first operation. It is recommended to 'run in' the oven before you cook. Run the oven at 180°C for 30 minutes and ensure that the room is well ventilated.
6. For products with a separate grill compartment, run grill on maximum for 15 minutes with grill door open.
7. If your appliance is fitted with solid hotplates, turn heat setting to high for 3 minutes to fully harden the hotplate coating.

INSTALLING OVEN ACCESSORIES

FITTING OVEN SHELVES

1. Ensure shelf orientation is correct (refer to diagram below).
2. Slide oven shelves onto oven supports (side runners) at an angle until raised back of shelf is past the stop on oven supports (side runners).
3. Lower front of shelf and push in until stop is reached.
4. To remove oven shelves, withdraw to the stop and raise the front of shelf to clear the stop.

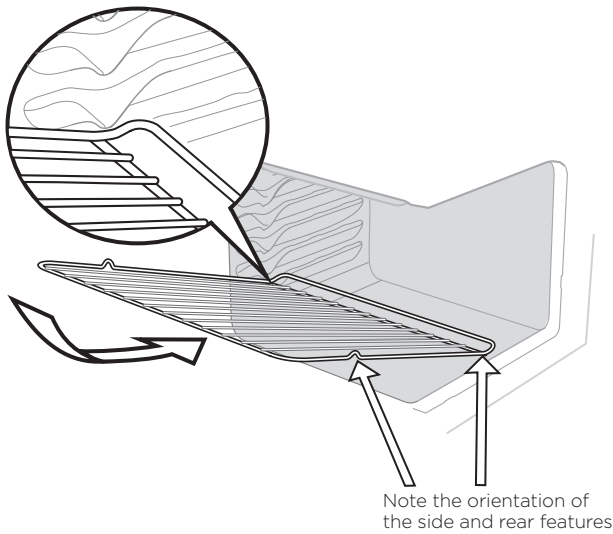

Oven shelf location

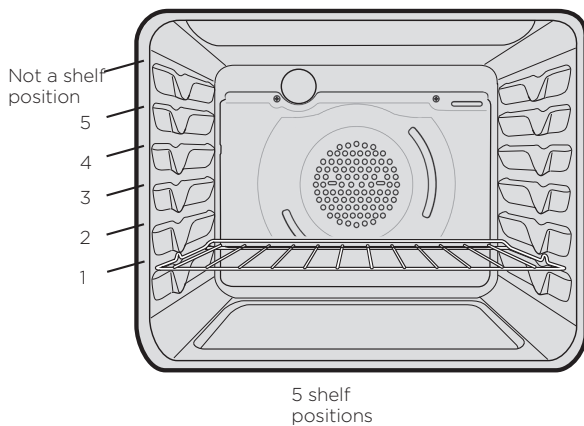

NOTE: the top ledge is not a shelf position. There are no stops for shelf withdrawal.

Fitting the grill dish supports

- Insert the rear hook into the rear hole.
- Align the front peg to the front hole and push in firmly.

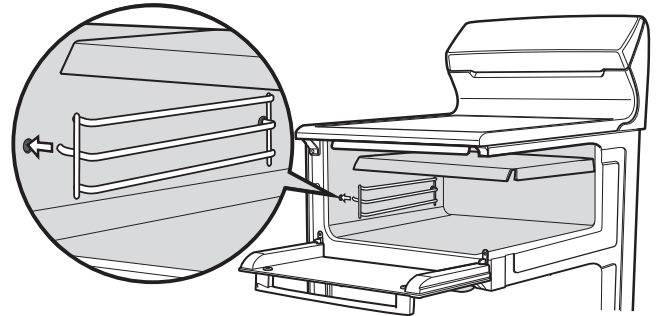

FITTING THE GRILL DISH

Separate grill

Ensure rear of the dish is engaged with the side support before sliding backwards. To remove, simply pull forwards and upwards.

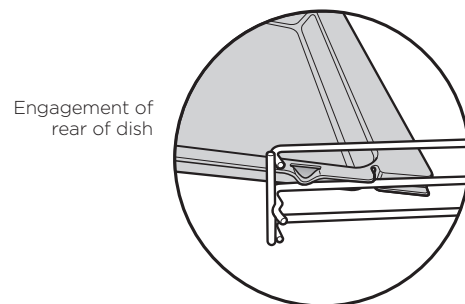

Grill in oven

(refer to Fitting Oven Shelves)

The grill dish with wire insert can be used in any of the two upper height positions (shelf positions 4 and 5) between the runners.

NOTE: You must remove the grill dish when baking in the oven.

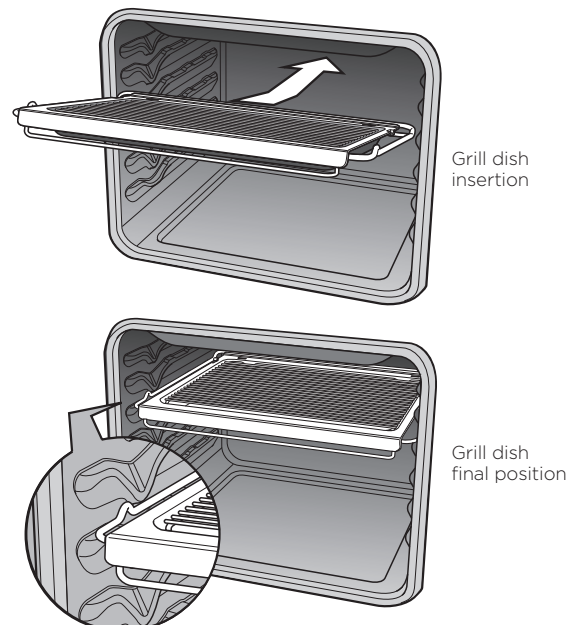

USING THE GAS COOKER

Gas oven features and descriptions

WLG510WCH

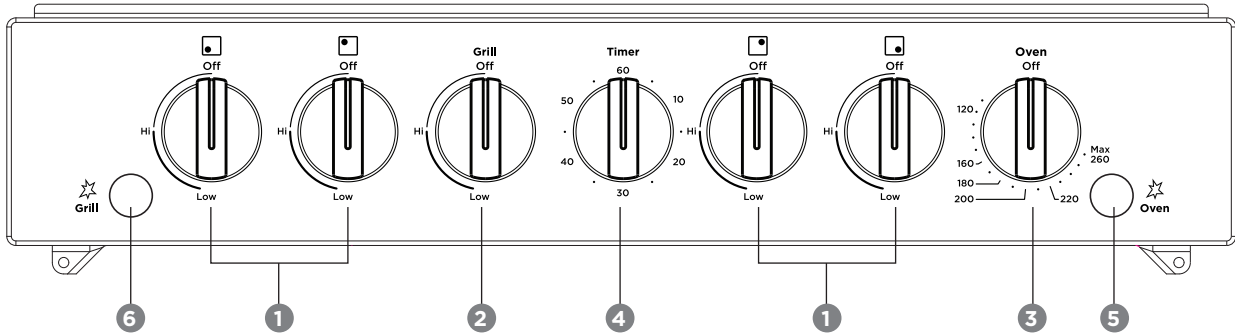

WLG510WCA

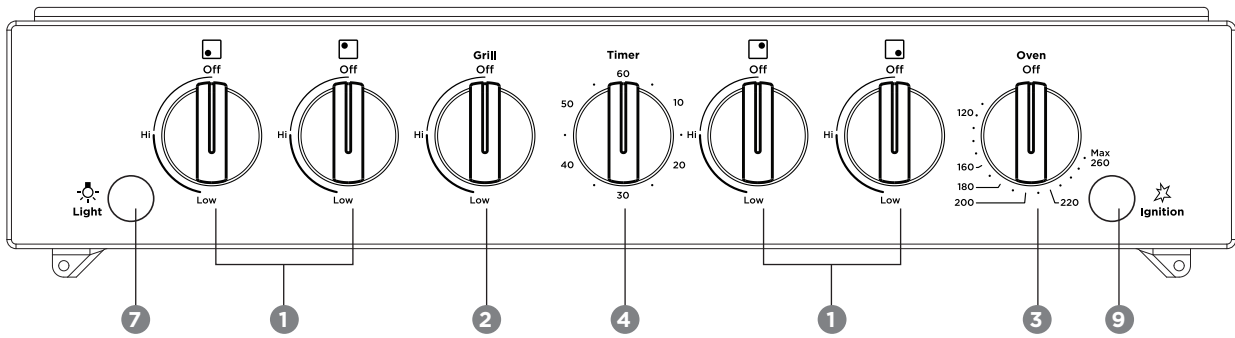

WLG512

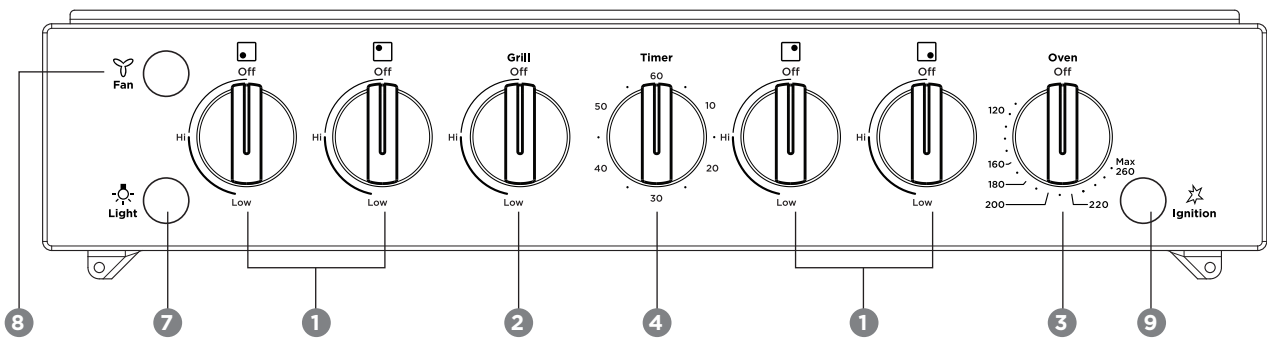

1. Burner Control Knob - sets burner temperature.
2. Grill Control Knob - sets grilling temperature.
3. Oven Control Knob - sets oven temperature.
4. Timer 60 Minute (where fitted) - sets reminder time. When timer returns to zero, timer gives a short ring.
NOTE: for any time below 15 minutes, turn knob past 15 minutes, then back to required time setting.
5. Oven Piezo Ignitor - ignites oven burner when appropriate control knobs are set.
6. Grill Piezo Ignitor - ignites grill burner.
7. Light Switch (where fitted) - turns oven light on/off.
8. Fan Switch (where fitted) - turns fan on/off.
9. Electronic Ignition Switch - ignites hotplate burners, grill burner and oven burner.

USING THE GAS COOKER

Gas oven conventional baking

The heat comes from the bottom oven burner. The temperature at the centre of the oven is the same temperature set on the control knob. When oven is used on this mode, shelf position is important, (refer to 'Oven Guide'). As hot air naturally rises, the upper half of the oven will be approximately 10°C higher and the lower half approximately 10°C cooler than the set temperature.

For best results from your gas oven use dark coloured trays and baking dishes on a single shelf. Refer to 'General Hints and Tips' section for more information.

For best baking results preheat oven for 30 minutes.

Gas oven fan forced baking

Fan Forced baking generally requires lower temperatures than conventional baking. Most recipe books, unless stated, are for conventional oven temperatures. It is recommended when using the fan forced mode to reduce the oven temperature by 10°C.

In a fan forced gas oven the heat comes from the bottom burner. Hot air is distributed by an electrically operated fan located behind the rear wall of the compartment, providing an even temperature on all shelf levels. This means batches of the same food can be baked using multiple shelf positions simultaneously.

Fan Forced operation can be used for single shelf baking with equal success.

For best baking results preheat oven for 30 minutes.

Cookware

For best baking results with gas ovens, dark coloured trays and baking dishes are recommended.

Gas hotplate

Ensure burner caps, crowns and trivets are properly assembled. For wok ONLY use the trivet and burner dedicated for wok cooking.

Burner cap and burner crown must be clean and located correctly for the burner to light.

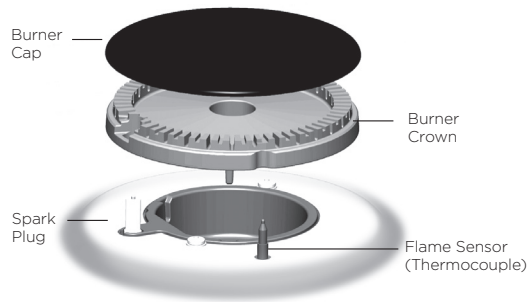
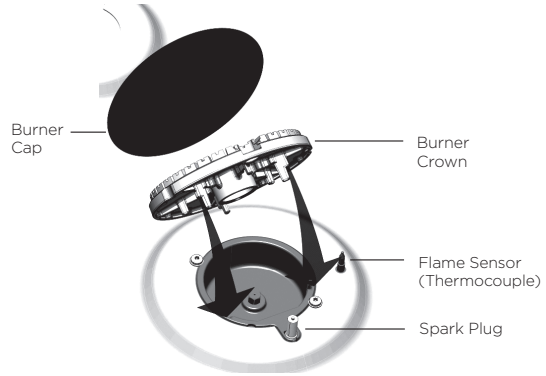

Gas oven burner flame

From a cold start the oven burner flame will be higher on the left hand-side. After reaching the set temperature, the flame will become even. This does not affect cooking results.

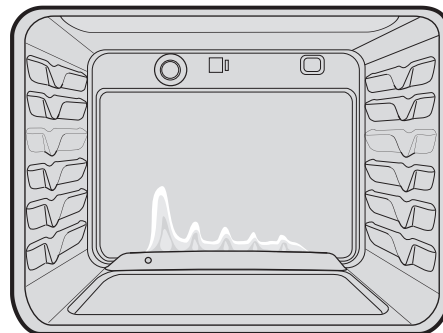

LIGHTING GAS COOKTOP, GRILL AND OVEN

Cooktop ignition - Electronic

This hob is fitted with mains powered electronic ignition. When the appliance has been connected and the power is on, depressing ignite button will release sparks to all burners.

To light a burner, depress the corresponding knob fully and turn anticlockwise to 'HI' position while continuing to depress the knob. The flame sensor must warm-up in order for the flame to stay alight.

The knob may be released once the flame is established, and turned further anticlockwise to reduce the flame height as desired.

- Before releasing the knob, ensure the knob is fully depressed.
- If the flame goes out when the knob is released, simply repeat the ignition procedure again.

Cooktop ignition - (Manual)

To light a burner, depress the corresponding knob fully and turn anti-clockwise to 'HI' position while continuing to depress the knob. At the same time hold hand-ignitor next to the burner and ignite (hand-ignitors not supplied). The flame sensor must warm up in order for the flame to stay alight.

Grill Ignition - Electronic

While pressing the electronic ignitor switch, depress the corresponding knob fully and while continuing to depress the knob, turn anti-clockwise to 'HI' position. The flame sensor must warm up in order for the flame to stay alight.

Grill Ignition - Piezo

Depress the grill control knob fully and while continuing to depress the knob, turn anti-clockwise to 'Hi' position, repeatedly press and release piezo ignite button to light gas. The flame sensor must warm up in order for the flame to stay alight.

Grill - in Oven

Grill is electric and is operated by control knob only.

Grill Ignition - (Manual)

To light a burner, depress the corresponding knob fully and while continuing to depress the knob, turn anti-clockwise to 'Hi' position. At the same time, hold hand-ignitor next to the burner and ignite (hand-ignitors not supplied). The flame sensor must warm up in order for the flame to stay alight.

Oven Ignition - Electronic

While pressing the Electronic Ignitor Switch, push turn and hold the Oven Control Knob to the desired temperature. Hold Control Knob in for 15 seconds after ignition.

Oven Ignition - Piezo

Push and hold the Oven Control Knob in and turn it a quarter of the way anti-clockwise. Keep the oven Control Knob pushed in firmly and at the same time push the Oven Piezo Ignitor button on the right hand side of the control panel (several times if necessary). It will make a loud 'clack' noise as the Piezo mechanism creates a spark. Hold control knob in for 15 seconds after ignition.

Oven Ignition - (Manual)

To light a burner, depress the corresponding knob fully and while continuing to depress the knob, turn anti-clockwise to 'Hi' position. At the same time, hold hand-ignitor next to the burner and ignite (hand-ignitors not supplied). The flame sensor must warm up in order for the flame to stay alight.

Ignition During Power Failure

Any gas burner can be manually ignited with a gas match (hand ignitor) - not supplied and used in the event of power failure.



WARNING

- Keep hands and clothing clear of burners when lighting.
- If burner does not light within 5 seconds, turn knob to 'Off' position, allow gas to disperse, then try lighting again.
- Burners MUST be operated between 'HIGH' and 'LOW' settings only.

USING THE ELECTRIC COOKER

ELECTRIC OVEN FEATURES AND DESCRIPTIONS

Grill in Oven Models

WLE524

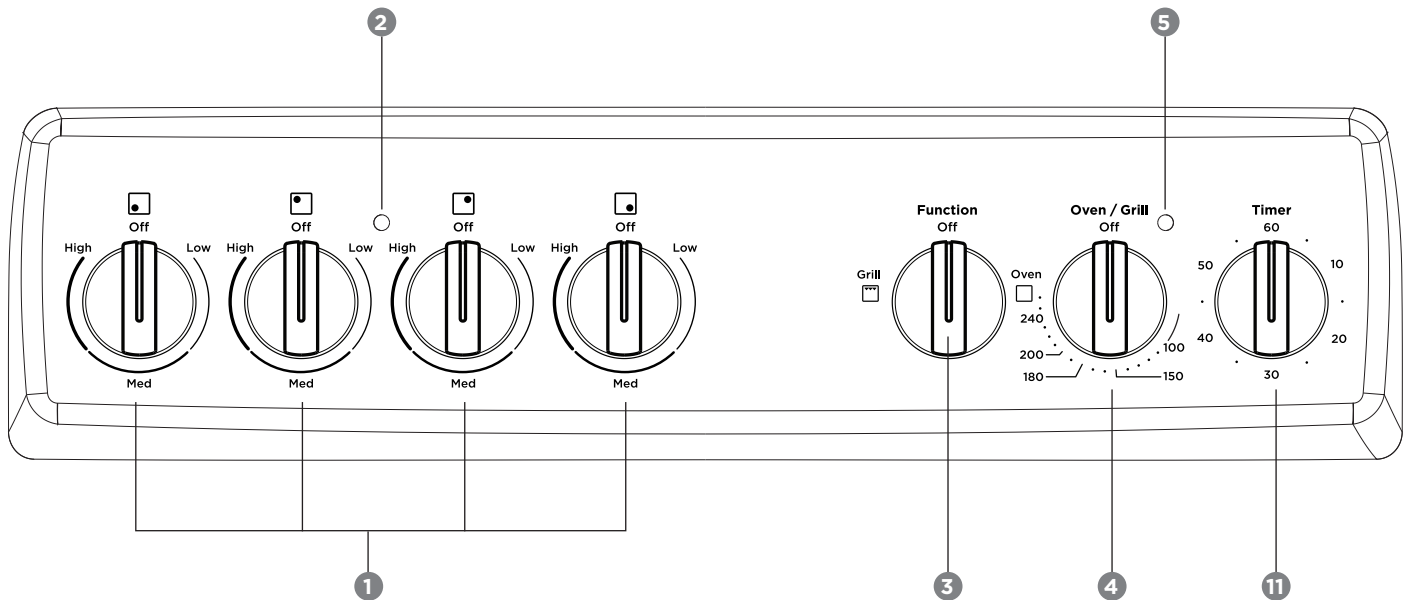

Separate grill models - conventional oven

WLE530

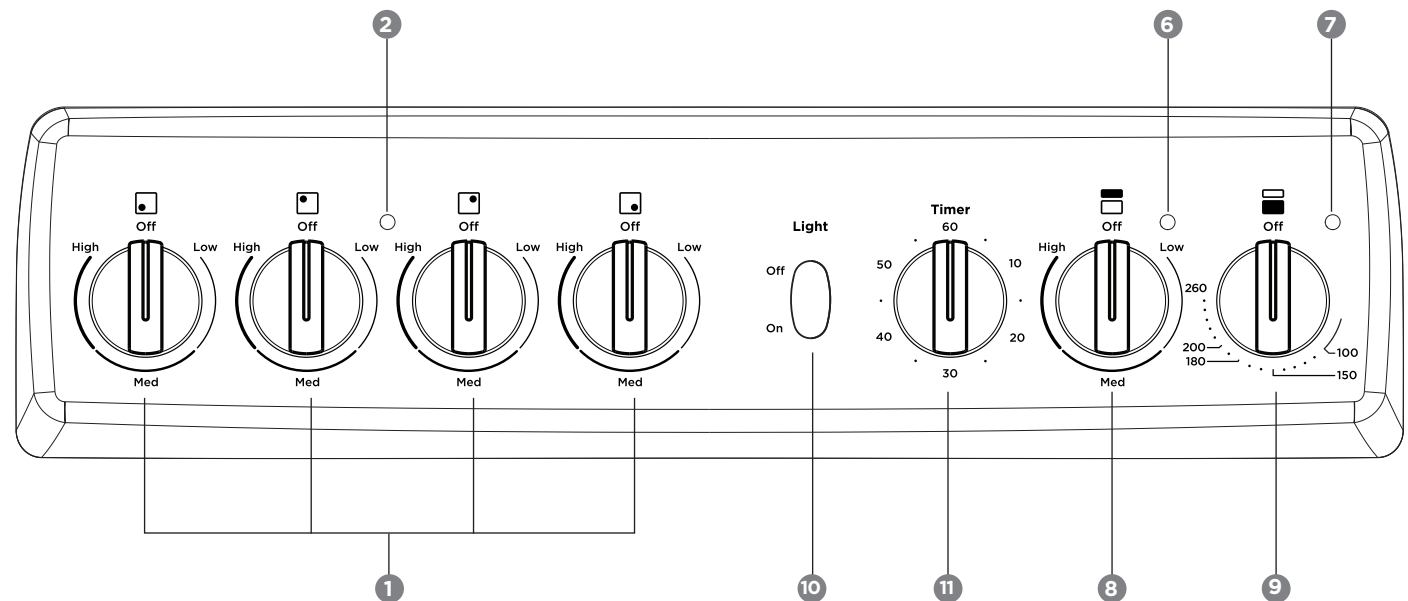

Separate grill models - fan-forced oven

WLE522/WLE532

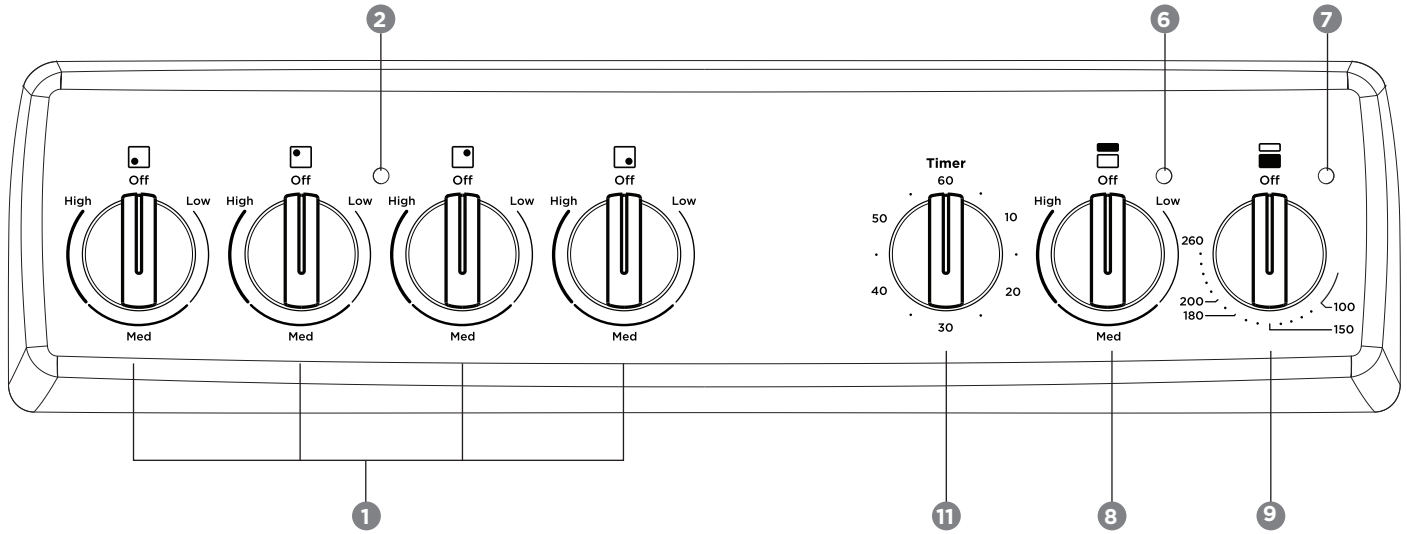

Separate grill models - fan-forced oven

WLE543

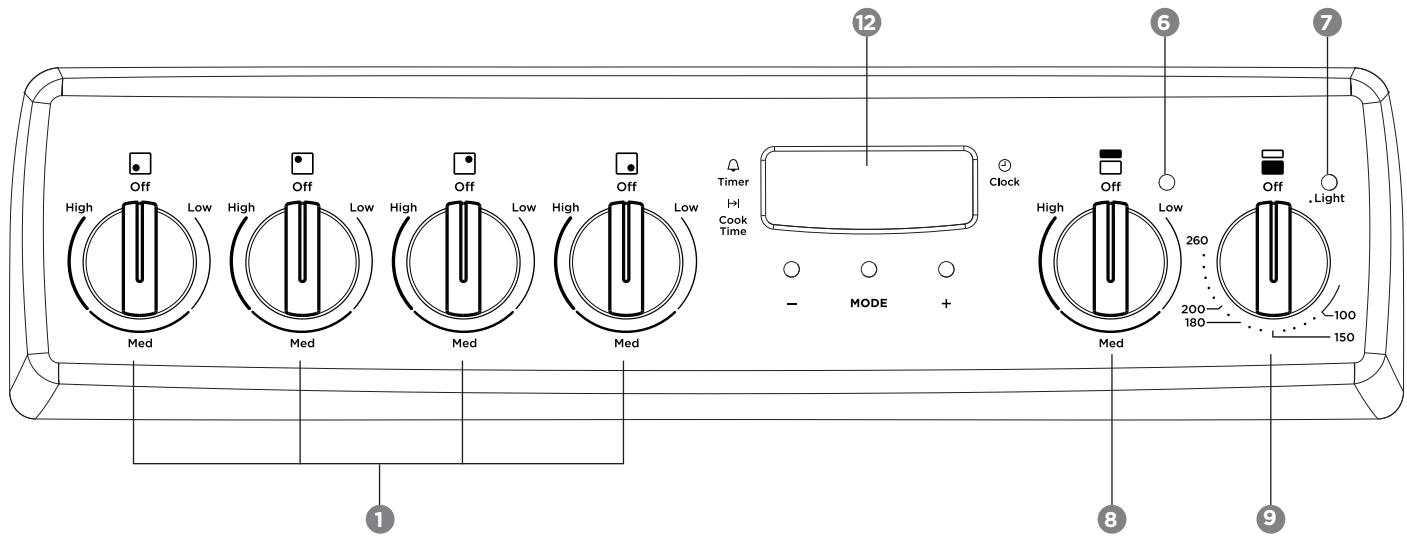

1. Radiant/Solid/Ceramic Hotplate Control Knob - sets hotplate temperature.
2. Hotplate Indicator Light - comes on when a hotplate control knob is operated.
3. Grill/Oven Function Control Knob - sets grill or oven function.
4. Grill/Oven Control knob - sets grill/oven temperature.
5. Grill/Oven Indicator Light - comes on when grill/oven temperature knob is operated. Oven indicator light cycles on and off when temperature is reached.
6. Grill Indicator Light - comes on when grill control knob is operated.
7. Oven Indicator Light - comes on when oven control knob is operated.
8. Grill Control Knob - sets grilling temperature.
9. Oven Control Knob - sets oven temperature.
10. Oven Light Switch - turns oven light on/off.
11. Timer 60 Minute - (where fitted) sets reminder time. - When timer returns to zero, timer gives a short ring. *NOTE: For any time below 15 minutes, turn knob past 15 minutes, then back to required time setting.*
12. Programmable Clock - sets baking/grilling reminder times - sets automatic cooking duration and stop time. *NOTE: Clock time must be set before operating oven.*

USING THE ELECTRIC COOKER

Radiant hotplates

The high-speed radiant hotplates heat rapidly from a cold start. This saves power.

The hotplates have a tray underneath the hob which collects spilt liquids. This tray can be removed by sliding it out through the open grill door (except model WLE524).

Radiant elements also swivel for easy cleaning.

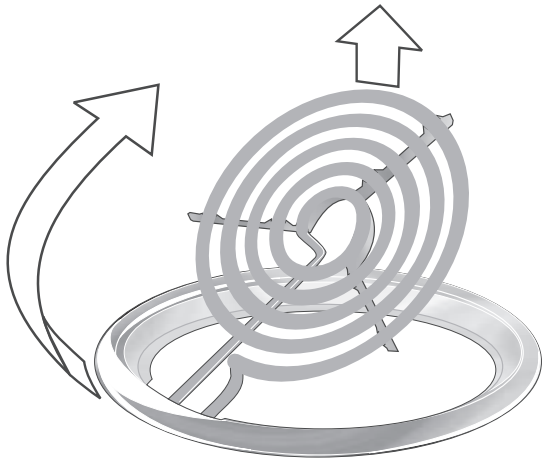

Solid hotplates

The strong solid-cast hotplates give wide contact for fast efficient cooking.

Hotplates are sealed to prevent spilt liquids from running under the hotplates.

If there is a red dot present in the centre of hotplate, this indicates it is a high power hotplate.

When necessary, apply a coating of hotplate protector to solid plates to maintain them.

Ceramic hotplates



WARNING

If the surface is cracked, switch off the appliance to avoid the possibility of electric shock.

- The ceramic cooktop is made from ceramic glass, a tough, durable material that withstands heating and cooling without breaking. However, it must be noted that as it is glass, it may break, and must therefore be treated with care. Should you have any questions about the glass in your new appliance, please contact the service centre by dialling 13 13 49.
- The smooth glass surface has a pattern to show where the elements under the glass are located.
- When a hotplate is on, the hot surface warning light will come on. After switching off, this light will continue to glow until the temperature of the hotplate drops below 60°C.

Electric oven conventional baking

Heat comes from two elements, one above and one below the food. The bottom element is hidden below the floor of the oven. As hot air rises naturally, the upper part of the oven will be approximately 10°C higher than the set temperature and the lower part of the oven approximately 10°C cooler.

For grill in oven models, the grill dish must be removed when baking.

For best baking results, preheat oven for 30 minutes, also refer to 'General Hints and Tips'.

Electric oven fan forced baking

In a fan forced electric oven the heat comes from the rear oven element. Hot air is distributed by a fan behind the rear wall of the compartment, providing an even temperature on all shelf levels. This means, batches of food can be baked using multiple shelf positions simultaneously.

Fan forced operation can be used for single food baking with equal success.

Fan Forced baking generally requires lower temperatures than conventional baking. Most recipe books, unless stated, are typically for conventional oven temperatures. It is recommended that when using the fan forced mode, reduce the oven temperature by 10 degrees (refer to 'Oven Guide').

For best baking results preheat oven for 30 minutes.



Cookware

For best cooking results with electric ovens, silver or shiny trays are recommended.

NOTE: Three button timer models MUST have clock set after a power outage to operate oven.

3 BUTTON PROGRAMMABLE CLOCK

Your oven is equipped with a 3 button timer that has the following features:

- Timer  - you can set a countdown time that will beep when the set time has elapsed.
- Cook time  - you can set cooking duration. A timer will count down the preset cooking time, beep when the time has elapsed and turn the oven off.

Selecting the timer

- Press the MODE button until the timer 'indicator' begins flashing.
- Set the countdown time you want by using the **-** and **+** buttons. 5 seconds after the last change the timer 'indicator' will stop flashing and the countdown will start in minutes.
- To stop the beeper, press any button.
- Maximum countdown time is 2hrs 30mins.





Setting the cooking duration

- Select the desired oven function and temperature.
- The oven indicator light will glow and the heating source will come on.
- Press the MODE button until the cook time  'indicator' begins flashing.
- Set the cooking duration you want by using the **-** and **+** buttons. 5 seconds after the last change the cook time 'indicator' will stop flashing, and the time of day will be displayed.

NOTE: Remember to add pre-heating time if necessary.



To check or cancel settings

- To check your settings, press the MODE button until the indicator you want is flashing.
- To cancel 'auto shut off' press the mode button until the 'cook time'  indicator flashes. Press and hold the **-** button until the clock no longer reverses (at 0:00 you will hear a beep). If you have left the temperature and function knobs at a setting, the oven will start once the 'cook time'  indicator stops flashing. Because you have cancelled 'auto off' the oven will continue to heat until you manually turn it off.

On completion of cooking

- The heat source will turn off, the timer will beep and cook time indicator will flash.
- Even though the heating element turns off the oven will still retain substantial heat. This will continue to cook the food until it is removed or the oven cools down. If you do not plan on being present when the oven turns off, you should take this extra heating time into account.
- Turn the function and temperature controls to the off position.
- Press any button to stop the timer beeping.

Adjusting the clock

- Press the MODE button until the clock  'indicator' begins flashing.
- Press the **-** or **+** buttons to change the time of day. 5 seconds after the last change, the clock 'indicator' will disappear, confirming the time has been adjusted.

GENERAL HINTS AND TIPS

CAUTION

Using the grill

Separate Grill	Grill with grill door open Grill dish must be fully inserted (Refer to SEPARATE GRILL DISH INSERTION)
Grill In Oven	Grill with oven door closed

General hints

For best baking results preheat oven for 30 minutes.

The material and finish of baking trays and dishes used will affect the way foods are baked, especially base browning.

- Enamelware, anodised aluminium, dark bakeware or non-stick interiors and coloured exteriors will assist in maintaining or reducing the baking time and increase base browning.
- Ovenproof glassware or ceramics are poor conductors of heat. The shiny surface of aluminium or polished steel utensils and trays also reflects the heat rather than passing it through to the food being baked.
- Always place dishes in the centre of the shelf to ensure even browning.
- Stand casserole dishes on a baking tray to prevent food from spilling onto the base of the oven.
- Use ovenproof cookware, which will withstand temperatures of 250°C.
- Use shallow casserole dishes in preference to deeper ones as this shortens cooking time in the oven.

CAUTION

- DO NOT place dishes, trays or baking pans directly on the oven base as they become very hot and will crack and craze the oven liner.
- DO NOT use baking trays larger than 30 x 35cm (12 x 14 inches) as they will restrict the circulation of the heat and may affect cooking performance of the oven.

Conventional Oven

- The shelf position is critical. The temperature in centre of the oven is the temperature shown on the oven control knob. Single shelf baking gives optimal cooking results.
- DO NOT place baking trays, oven dishes or foil directly on the base of oven, as trapped heat will crack and craze the floor of the oven liner.

Fan Forced

- Make sure shelves are evenly spaced.
- When baking more than one dish in fan forced oven, place dishes centrally on shelves rather than several dishes on one shelf.
- When the oven is full you may need to allow a slightly longer baking time.
- When using different size trays or cooking different types of food, cooking times may vary for each dish.

CAUTION

- DO NOT place baking trays and oven dishes directly against the grid covering the fan at the back of the oven.
- DO NOT place oven dishes directly on the oven base.

TIPS AND INFORMATION

Condensation and steam

- During cooking steam may be produced which can be released when opening the oven door. This is quite normal.
- If there is any build-up of condensation on the oven door it is recommended that it be carefully wiped away either during or after cooking.

WARNING

Always stand back from heated oven when opening oven door to allow any build-up of steam or heat to release.

SEPARATE Grill dish insertion

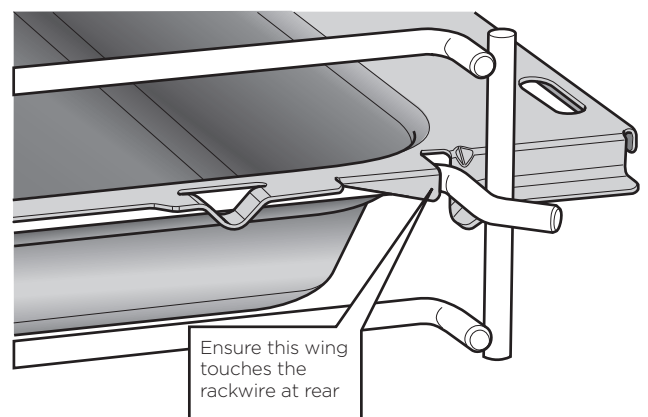

WARNING

Door glass is a tough and durable material designed to withstand heating and cooling without breaking. However it must be remembered that it is glass and may break, therefore must be treated with care. If you have any questions about the glass in the oven please contact the Service Centre on 13 13 49.

GETTING TO KNOW YOUR OVEN

Getting to know your new oven with this simple 'Test Cake'

When baking, it is normal to experience some slight variation in temperature throughout the oven, resulting in minor differences in colour of the items being baked. You may need to rotate items whilst cooking to ensure an even colour.

SIMPLE 'Test Cake'

125g butter, softened to room temperature.

1 cup caster sugar.

1 teaspoon pure vanilla essence.

4 large eggs.

2 cups self-raising flour.

Pinch of salt.

4 tablespoons (80ml) full-cream milk.

Method:

1. Butter base and sides of two, 20cm straight-sided round or square cake pans. Then line the base with grease proof paper or baking paper.
2. Preheat oven to moderate 180°C (170°C fan forced) for 30 minutes and ensure oven shelf is in position 2 of the oven.
3. Cream softened butter and sugar until light in colour.
4. Add vanilla essence.
5. Add eggs one at a time, beating well after each addition.
6. Sift flour and salt into the mixture and beat until well combined.
7. Add milk and beat or stir to combine.
8. Spoon mixture equally between prepared cake pans.
9. Bake in preheated oven, position 2 for about 25 to 35 minutes. Tip: Insert a fine cake skewer into the cake mix. If it comes out clean, or if the edges of the cake have come away slightly from the sides of the cake pan, the cake is ready.
10. Remove from oven and place on wire cake rack and rest for 5 minutes before removing from cake pans. Cool completely.

To Serve: sandwich together with your favourite jam or conserve, and dust top with pure icing sugar.

NOTE: if desired, substitute butter for either margarine or olive oil spread.

Recipe is based on the Australian standard metric 250ml cup and 20ml tablespoon sets.

GENERAL HINTS AND TIPS

Cleaning the oven door

Cool air circulates through the door to lower the surface temperature on the outside of the oven door.



CAUTION

- Do not remove the outer oven door. This product has a removable inner glass insert for ease of cleaning.

To remove the inner door glass for cleaning

- Open the door fully to access the hinges then rotate the 'stirrups' on both hinges fully towards the door.

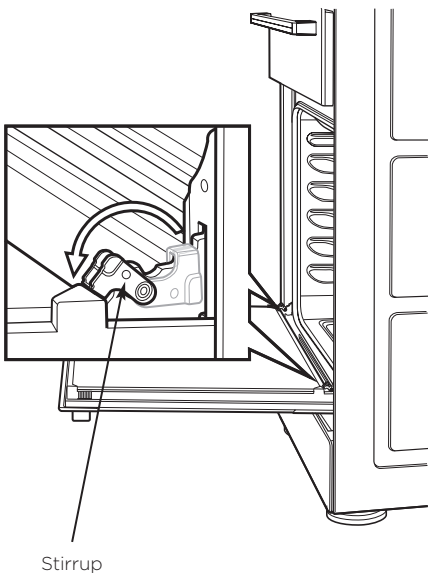

- Slowly close the door until it stops against the 'stirrups'.

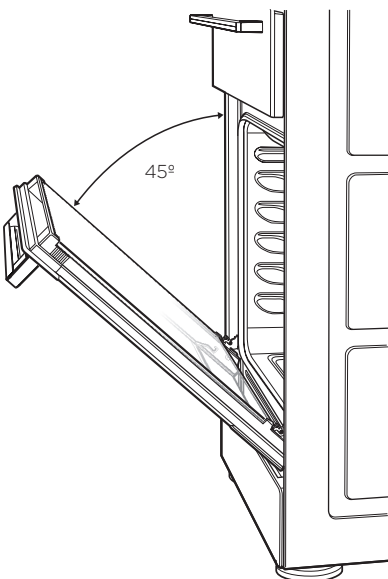

- To remove the top caps, press the ribbed release clips at each end and lift top cap away from the door.

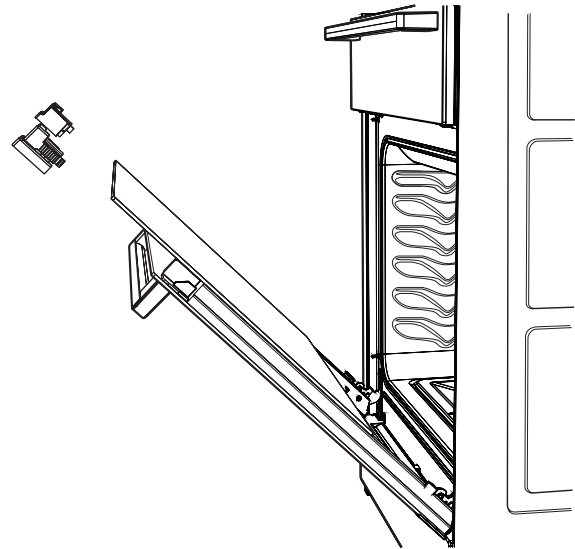

- Using both hands, gently remove the inner glass by sliding out and lifting away from the door.

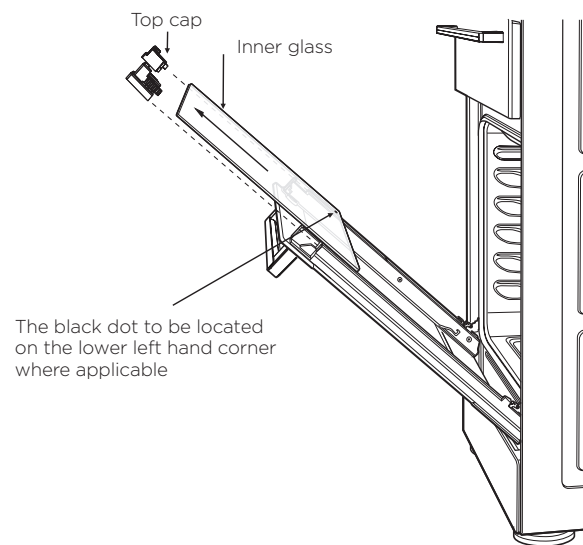

- Hand wash only with a soft cloth and warm soapy water. When dry, polish with a soft cloth and ensure the glass is dry before re-assembly.
- Wipe inner and outer glass gently with detergent and warm water.
- Wipe clean and dry thoroughly.

Re-Assembling the oven door inner glass

- Replace the top caps ensuring the clips snap back into position.
- Fully open the door, rotate the stirrups back to their original position and close the door.
- When replacing the door inner glass, make sure the black dot is positioned as shown in the image (where applicable).

WARNING

- DO NOT use the oven without the inner door glass fitted.
- DO NOT use harsh abrasives on glass as this may damage the glass.
- DO NOT place glass in dishwasher.

SAFETY WARNINGS ABOUT CLEANING

WARNING

- ALWAYS make sure that the cooker is turned off before cleaning.

CAUTION

- ALWAYS clean cooker immediately after use.
- DO NOT use steam cleaners. These may cause moisture build-up, especially in the glass door.
- DO NOT use caustic based cleaners or harsh abrasives. These will damage your oven.

Door glass

- DO NOT use harsh abrasive cleaners or sharp metal scrapers to clean glass since they can scratch the surface, which may result in shattering of the glass.

Replacing the oven light

WARNING

Ensure the appliance is switched off at power supply (not just the control knobs) before replacing the light globe to avoid possibility of electric shock.

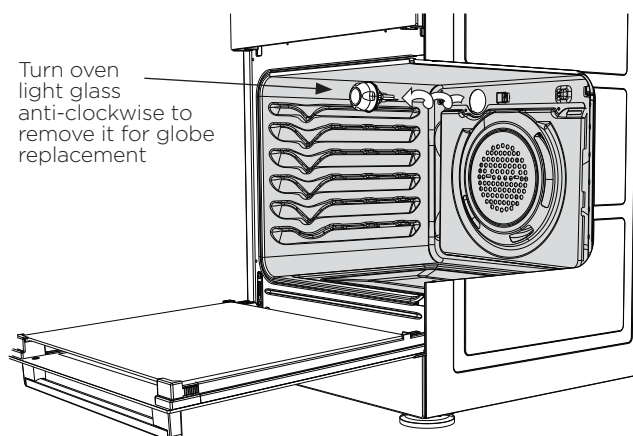

A special high temperature resistant globe should be used. This can be purchased from the Electrolux Customer Care Centre.

Light globes are not covered by warranty.

CLEANING THE COOKER

Ovens and hotplates are made from steel and enamel. Do not use abrasives and harsh scourers as they may scratch the surface.

Enamel

- Keep enamel clean by wiping it with a soft cloth dipped in warm soapy water.
- Rub difficult stains with a nylon scourer or cream powder cleanser.
- DO NOT use abrasive cleaners, powder cleaners, steel wool or wax polishes.
- If you use an oven cleaner, follow the instructions on the product carefully.

Stainless Steel

- All grades of stainless steel can stain, discolour or become greasy. Clean the cooker regularly, using the procedures outlined below, to maintain the function and appearance of your appliance.
- Care must be taken when wiping exposed stainless steel edges as they can be sharp.
- The front frame around the oven can be cleaned with stainless steel cleaners if it becomes soiled or discoloured.
- A suitable cleaner can be purchased from Electrolux Customer Care Centres.
- Always clean the stainless steel in the direction of the grain. Going against the grain may scratch the surface.

Oven Shelves

- Chrome shelves: use detergent and hot water. If very dirty use a non-abrasive nylon scourer.

Oven - Grill Dish and Insert

- After every use and while still warm, wash pan and grill with warm soapy water and a suitable oven cleaner. Rinse and dry before replacing in position.

Oven

- Use detergent, warm water (and household cloudy ammonia if necessary) and a soft cloth. Dry thoroughly.
- Remove shelves when cleaning the oven.
- If there is a build-up of grease use a suitable oven cleaner, following the instructions on the cleaning product carefully. Heat oven to 110°C and turn oven off when 110°C is reached. Leave over-night. The fumes will loosen stubborn grease and stains. Remove bowl, wash with hot, soapy water and dry well before closing oven door again. Ensure oven is thoroughly rinsed and dried before subsequent use.



CAUTION

DO NOT remove the oven door when cleaning the oven.

Ceramic hotplates

Remove all spilt food with a razor blade scraper while the hotplate is still warm – NOT HOT.

- If aluminium foil, plastic items or foods with a high sugar content melt onto glass, use a razor blade scraper to remove immediately before the hotplate has cooled, otherwise pitting of the surface may occur. High sugar content foods include jam, fruit, carrots, tomatoes and peas.
- Sometimes SURFACE stains appear to be 'bubble' marks under the ceramic glass. These can be cleaned off with a razor blade scraper and ceramic cleaner.
- When the ceramic hotplate has cooled, wipe clean with dishwashing detergent and a damp cloth.

NOTE: DO NOT use abrasive sponges or scourers, oven sprays or stain removers on ceramic hotplates. These may damage, scratch or stain the ceramic cooktop. Any pitting, staining or scratching WILL NOT be covered by warranty.

Solid hotplates

Solid hotplates are fitted with stainless steel trim rings, which after initial use, change colour to light brown. This is a normal characteristic of stainless steel and will not affect the operation or performance of your hotplates.

- Clean off any spillage after hotplate has cooled down.
- At regular intervals, clean hotplate with a nylon scouring pad and soapy water. Wipe clean then warm hotplate for 30 seconds to dry the surface.
- Apply 'hotplate protector'. Set hotplate on high for 3 minutes to allow coating to harden.

Radiant hotplates

These plates are self cleaning. Any liquid which boils over will burn to ash and can be wiped off when the hotplate has cooled. To clean the trim rings, lift front of element and remove, then wash in warm, soapy water.

To clean any spillage that falls through the element, remove the spillage tray and wash in warm soapy water.

CLEANING THE COOKER

Gas burners

- Flame port blockages should be removed with a small metal cake skewer or nylon brush.
- Clean dirty spark plugs very gently with a nylon scourer. Do not use steel wool. Do not bend spark plug as it may break.
- If the caps, crowns and cups are heavily soiled, use a non-abrasive cleaning compound.
- Do not clean these parts with abrasive or caustic type cleaners, or clean in a dishwasher as they will be damaged.

Ignition spark plug and flame safeguard sensor

GENTLY clean the ignition spark plug and flame safeguard sensor with a damp cloth to avoid lighting difficulties. Ensure that they are dry before use.

Injector

Ensure the injector remains free of any foreign material. When cleaning the burner spill bowl, first put tape over the injector hole before wipe out the spill bowl to avoid to block the injector hole, then remove the tape after cleaning.

If necessary, use a thin piece of wire to clear the orifice.

Do's	Don'ts
Use pots with a flat base	Do not slide pots across the glass as this can result in scratches to the surface
Clean when cold unless sugar spills which should be removed with a ceramic scraper	Do not clean when hot as it is dangerous and cleaning products can burn and stain
Clean after every use with a sponge and soapy water then dry	Do not leave food residues or water on the ceramic as the contamination can damage the ceramic and screening printed graphics
Use a non-scratch scourer (usually blue in colour) if required	Do not use steel wool or scourer pads that are not specified as non-scratch (usually green in colour). Heavy duty scourers are too abrasive
Difficult stains should be removed with a ceramic scraper and cleaning cream specific for ceramic glass cooktops Cerapol	Do not use general abrasive cleaners as these can cause micro-scratches, dulling the glass surface and increasing the likelihood of contamination embedding into the glass
At least once per week use ceramic sealer cream Ceraseal	Do not use the ceramic top as a cutting board or work bench as this will cause scratches

CLEANING THE COOKER

Ceramic Cooktop Cleaning

CUSTOMER ADVICE

Sometimes SURFACE stains appear to be a "bubble" mark under the ceramic glass.

These can be cleaned off with a razor blade scraper and ceramic cleaner.

Keeping the ceramic cooktop clean and protected will keep it in good condition and help avoid breakage.



Ceramic Scraper
0383001001



Cerapol Cleaner
ACC019



Ceraseal Protector
ACC018

Available at the following web shops.
<https://shop.electrolux.com.au>

If the deposit is minimal, simply wipe off with a dry cloth.

If the deposit is more stubborn, clean off with a moist soapy sponge then rinse off.

If the deposit still does not clean off easily, use a non-abrasive nylon scratch pad and special purpose ceramic glass cleaning agent such as Cerapol cleaner (ACC019 - Available from our web shop).

If the deposits are still burnt on and above methods did not work, use a specially designed ceramic glass scraper (0383001001 - Available from our web shop).

After having successfully cleaned the cooktop, apply a ceramic glass conditioner Ceraseal protector (ACC018 - Available from our web shop). The conditioner will leave a protective coating that will help prevent future stains from becoming baked on. Marks which appear to be bubbles under the ceramic will also clean off. Use Ceraseal (ACC018) to help protect the ceramic and allow for easier cleaning. Polish on with a dry clean cloth.

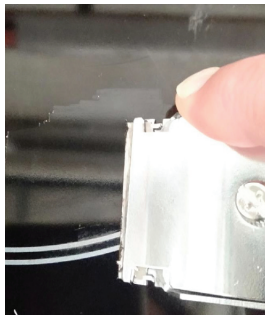
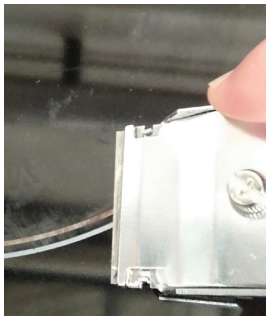

Marks which appear to be bubbles under the ceramic will also clean off.



Use Ceraseal (ACC018) to help protect the ceramic and allow for easier cleaning. Polish on with a dry clean cloth.



CLEANING THE COOKER

Stainless Steel Cooktop Cleaning

NOTE: Ensure any oil is cleaned off the hob before use, otherwise it may cause the hob to turn a yellowish colour. All grades of stainless steel may stain, discolour or attain an adhering layer of grime in normal operation. To achieve maximum surface appearance, stainless steel must be kept clean.

Do's	Don'ts
Clean in the direction of stainless steel brushing lines	Do not clean against the stainless steel brushing lines as this will cause scratching
Wash with warm soapy water	Do not use caustic cleaners
For stains use a specific stainless-steel cleaner ACC031	Do not use abrasive cleaners, scourers or steel wool as this will cause scratching
Always clean the stainless steel after food spillage	Some foods may discolour the stainless steel
Use the correct sized pot as described in the owner manual	Do not oversized pots as they can reflect heat onto the stainless steel causing discolouration

NOTE: Do not use stainless steel cleaners on oven doors or control panels with finger print proof coating. Refer to owner manual for specific models.



Steel Klean
ACC032



Steel Power
ACC031

Available at the following web shops or distributors.
<https://shop.electrolux.com.au>

Remove deposits with a soft cloth and warm soapy water then wipe with a dry soft cloth. If there are signs of yellowing or stubborn stains, use a suitable stainless steel cleaner Steel Klean (ACC032 - Available from our web shop), apply with a soft cloth and clean in the direction of the stainless steel grain only.

After the cooktop is clean, apply stainless steel protectant Steel Power (ACC031 - Available from our web shop) which will leave a protective coating to help prevent future stains from occurring.

Before

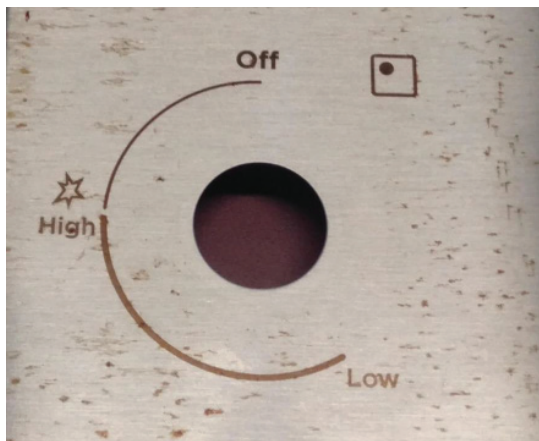

After

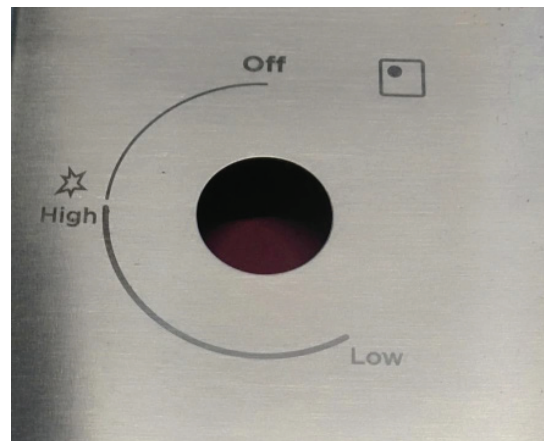

OVEN GUIDE

The following is intended as a guide. Cooking variation is natural and to be expected. You should experiment with times, temperatures and recipes to obtain the best results to your own taste. Get to know your oven before making a service call. Where the gas models vary from the electric models, details for gas cooking is shown in brackets. For best results when baking, preheat your oven for 30 minutes.

FOOD	CONVENTIONAL OVEN		FAN FORCED OVEN		TIME IN MINUTES
	Temperature °C	Oven shelf position*	Temperature °C	Oven shelf position*	
Plain or fruit scones	220	2 (3)	210	Any	10 -15
Rolled biscuits	170 (180)	2	150 (170)	Any	10 -15
Spooned biscuits	190	2	180	Any	12 -15
Shortbread biscuits	160	1 or 2	150	Any	30 - 35
Hard individual meringues	110	2	100	Any	90
Soft individual meringues	180	2	165	Any	15 - 20
Pavlova - 6 eggs	110 (120)	1	100	Any	75
Patty cakes	190	2	180	Any	15 - 20
Sponge - 4 eggs	180	2	170	Any	20 - 30
Plain butter cake	180	2	170	Any	25 - 40
Rich fruit cake	140 (150)	2	130	Any	180
Shortcrust cornish pasty#	200 (200/180)	2	180 (180/160)	Any	40 - 45 (10/35)
Shortcrust custard tart	200/180 (220/180)	1(3)	190/170 (200/180)	Any	20 - 30 (10/25)
Cream puffs	210	2	200	Any	25 - 30
Yeast bread	210	1	200	Any	25 - 30
Pizza	220	2	220	Any	15 - 25

* Shelf position is counted from the bottom shelf up. Bottom shelf position is 1.

Turn down temperatures shown.

MEAT/POULTRY/FISH	RECOMMENDED TEMPERATURE °C	MINUTES PER KILOGRAM
- Rare	200	35 - 40
Beef	- Medium	200
	- Well done	200
Lamb	- Medium	200
	- Well done	200
Veal	180	60
Pork	200	60
Chicken	180 - 200	45 - 50
Duck	180 - 200	60 - 70
Turkey	180	40 - 45 (less than 10kg)
		35 - 40 (more than 10kg)
Fish	180	20

TROUBLE SHOOTING

If you have a problem with your appliance check the following before you ring the call service.

PROBLEM	WHAT TO DO
Operational problems i.e. Oven, grill or hob not working	<p>Check the electricity is turned on</p> <p>Check your fuses. If the fuse continues to blow, call the Service Centre</p> <p>Check the circuit breaker</p> <p>Ensure correct knob is turned</p> <p>Gas only – Dry or clean ignition electrodes</p> <p>Gas only – Make sure flame ports and ignition areas are clean and dry</p> <p>Gas only – Check gas supply is on</p> <p>Gas only – Ensure cap/crown correctly fitted</p> <p>Replace or tighten light globes (where fitted)</p>
Heat up problems	<p>Oven not pre-heated – Pre-heat oven for 30 minutes</p> <p>Check oven door is closed properly</p> <p>Remove foil or trays from bottom of oven</p> <p>Change set oven temperature</p> <p>Preheat your oven/grill before you put the food in to be cooked</p>
Unit smoking odours	<p>New appliances can have an odour during first operation. It is recommended to 'run in' the oven before you cook. Run the oven at 180°C for two hours and ensure room is well ventilated</p> <p>For products with separate grill compartment, run the grill on for full for 15 minutes with grill door open</p> <p>Persistent gas smell – do not operate appliance. Call service 1313 49</p>
Condensation <i>NOTE: some condensation is normal and is to be expected during cooking</i>	<p>Reduce the amount of water used for cooking</p> <p>Leave the door open after cooking if food remains in cooker for warming</p>
Timer not audible	Turn Timer knob past 15 minute mark then to the required number of minutes
Oven shelf tight	Remove shelf and insert as per diagram
Oven or grill not working (Electric cooker only)	Set time on clock
Oven not working	Clock program set. Cancel program
Oven light not working	Lamp blown or loose in socket. Replace or tighten globe
Electronic clock flashing on display or off (Electric cooker only)	Check household power supply, fuses and reset time of the day
Powerpoints not working (NZ model Electric cooker only)	Check the fuse at rear and replace if blown
Gas oven burner uneven flame	This does not affect cooking results. From cold start the oven burner flame will be higher on the left-hand side. After reaching the set temperature, the flame will then be even
The oven seal is loose	The oven seal is attached at each corner. It may seem like a loose fit, but when the oven door is closed it will function correctly

tips and information

When you need information, service or replacements please quote:

1. Model Number.
2. Serial Number: You can find these on the data plate, which can be seen when the oven door is open. If you need more information, please contact the Customer Care Centre on 13 13 49 (Australia – Centre is open 8.00am to 5.00pm Monday to Friday EST).

Or 0800 436 245 (New Zealand – Centre is open 8.00am to 5.00pm Monday to Friday).

Only authorised service centres should carry out servicing or warranty may be voided.

If you have a warranty or spare parts enquiry, you should call the numbers listed on the back page.



FOR SALES IN AUSTRALIA AND NEW ZEALAND
 APPLIANCE: WESTINGHOUSE BUILT-IN OVENS, COOKTOPS AND
 FREESTANDING COOKER

This document sets out the terms and conditions of the product warranties for Westinghouse Appliances. It is an important document. Please keep it with your proof of purchase documents in a safe place for future reference should there be a manufacturing defect in your Appliance. This warranty is in addition to other rights you may have under the Australian Consumer Law.

1. In this warranty:

- (a) 'ACL' or 'Australian Consumer Law' means Schedule 2 to the Competition and Consumer Act 2010;
- (b) 'Appliance' means any Electrolux product purchased by you and accompanied by this document;
- (c) 'ASC' means Electrolux's authorised serviced centres;
- (d) 'Westinghouse' is the brand controlled by Electrolux Home Products Pty Ltd of 163 O'Riordan Street, Mascot NSW 2020, ABN 51 004 762 341 in respect of Appliances purchased in Australia and Electrolux (NZ) Limited (collectively "Electrolux") of 3-5 Niall Burgess Road, Mount Wellington, in respect of Appliances purchased in New Zealand;
- (e) 'Warranty Period' means the period specified in clause of this 3 warranty;
- (f) 'you' means the purchaser of the Appliance not having purchased the Appliance for re-sale, and 'your' has a corresponding meaning.

2. Application: This warranty only applies to new Appliances, purchased and used in Australia or New Zealand and is in addition to (and does not exclude, restrict, or modify in any way) other rights and remedies under a law to which the Appliances or services relate, including any non-excludable statutory guarantees in Australia and New Zealand.

3. Warranty Period: Subject to these terms and conditions, this warranty continues in Australia for a period of 24 months and in New Zealand for a period of 24 months, following the date of original purchase of the Appliance.

4. Repair or replace warranty: During the Warranty Period, Electrolux or its ASC will, at no extra charge if your Appliance is readily accessible for service, without special equipment and subject to these terms and conditions, repair or replace any parts which it considers to be defective. Electrolux may, in its absolute discretion, choose whether the remedy offered for a valid warranty claim is repair or replacement. Electrolux or its ASC may use refurbished parts to repair your Appliance. You agree that any replaced Appliances or parts become the property of Electrolux.

5. Travel and transportation costs: Subject to clause 7, Electrolux will bear the reasonable cost of transportation, travel and delivery of the Appliance to and from Electrolux or its ASC. Travel and transportation will be arranged by Electrolux as part of any valid warranty claim.

6. Proof of purchase is required before you can make a claim under this warranty.

7. Exclusions: You may not make a claim under this warranty unless the defect claimed is due to faulty or defective parts or workmanship. This warranty does not cover:

- (a) globes, light batteries, filters or similar perishable parts;
- (b) parts and Appliances not supplied by Electrolux;
- (c) cosmetic damage which does not affect the operation of the Appliance;

(d) damage to the Appliance caused by:

- (i) negligence or accident;
- (ii) misuse or abuse, including failure to properly maintain or service;
- (iii) improper, negligent or faulty servicing or repair works done by anyone other than an Electrolux authorised repairer or ASC;
- (iv) normal wear and tear;
- (v) power surges, electrical storm damage or incorrect power supply;
- (vi) incomplete or improper installation;
- (vii) incorrect, improper or inappropriate operation;
- (viii) insect or vermin infestation;
- (ix) failure to comply with any additional instructions supplied with the Appliance;

In addition, Electrolux is not liable under this warranty if:

- (a) the Appliance has been, or Electrolux reasonably believes that the Appliance has been, used for purposes other than those for which the Appliance was intended, including where the Appliance has been used for any non-domestic purpose;
- (b) the Appliance is modified without authority from Electrolux in writing;
- (c) the Appliance's serial number or warranty seal has been removed or defaced;

8. How to claim under this warranty: To enquire about claiming under this warranty, please follow these steps:

- (a) carefully check the operating instructions, user manual and the terms of this warranty;
- (b) have the model and serial number of the Appliance available;
- (c) have the proof of purchase (e.g. an invoice) available;
- (d) telephone the numbers shown below.

9. Australia: For Appliances and services provided by Electrolux in Australia: Electrolux goods come with guarantees that cannot be excluded under the Australian Consumer Law. You are entitled to a replacement or refund for a major failure and for compensation for any other reasonably foreseeable loss or damage. You are also entitled to have the Appliance repaired or replaced if the Appliance fails to be of acceptable quality and the failure does not amount to a major failure. 'Acceptable quality' and 'major failure' have the same meaning as referred to in the ACL.

10. New Zealand: For Appliances and services provided by Electrolux in New Zealand, the Appliances come with a guarantee by Electrolux pursuant to the provisions of the Consumer Guarantees Act, the Sale of Goods Act and the Fair Trading Act. Where the Appliance was purchased in New Zealand for commercial purposes the Consumer Guarantee Act does not apply.

11. Confidentiality: You accept that if you make a warranty claim, Electrolux and its agents including ASC may exchange information in relation to you to enable Electrolux to meet its obligations under this warranty.

Important Notice

Before calling for service, please ensure that the steps listed in clause 8 above have been followed.

AUSTRALIA	FOR SERVICE or to find the address of your nearest authorised service centre in Australia PLEASE CALL 13 13 49 <small>For the cost of a local call</small>	FOR SPARE PARTS or to find the address of your nearest spare parts centre in Australia PLEASE CALL 13 13 50 <small>For the cost of a local call</small>
NEW ZEALAND	FOR SERVICE or to find the address of your nearest authorised service centre in New Zealand PLEASE CALL 0800 10 66 10	FOR SPARE PARTS or to find the address of your nearest spare parts centre in New Zealand PLEASE CALL 0800 10 66 20

For more information on all Westinghouse appliances, or for dimension and installation information, call into your retailer, phone or email our customer care team or visit our website:

AUSTRALIA

phone: 13 13 49

fax: 1800 350 067

email: customercare@electrolux.com.au

web: westinghouse.com.au

NEW ZEALAND

phone: 0800 436 245

fax: 0800 225 088

email: customercare@electrolux.co.nz

web: westinghouse.co.nz

 and WESTINGHOUSE are trademarks of Westinghouse Electric Corporation.
Used under license. All Rights Reserved.

W_MAN_540UM_A21384504 Rev_B_Mar 26

© 2024 Electrolux Home Products Pty Ltd.
ABN 51 004 762 341